

IM2056
08/2017
REV01

POWER WAVE[®] ADVANCED MODULE & ADVANCED MODULE ALUMINUM

OPERATOR'S MANUAL

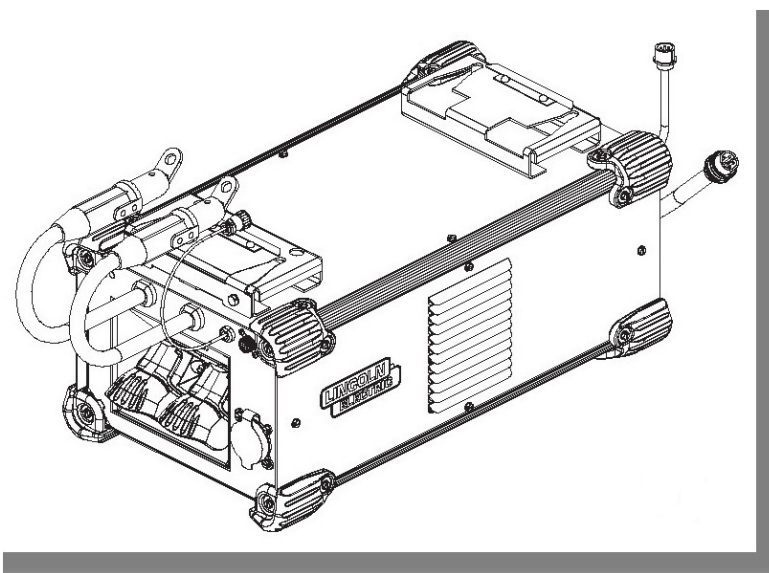

ENGLISH



THE LINCOLN ELECTRIC COMPANY
22801 St. Clair Ave., Cleveland Ohio 44117-1199 USA
www.lincolnelectric.eu

THE LINCOLN ELECTRIC COMPANY

EC DECLARATION OF CONFORMITY



Manufacturer and technical
documentation holder:

The Lincoln Electric Company
22801 St. Clair Ave.
Cleveland Ohio 44117-1199 USA

EC Company:

Lincoln Electric Europe S.L.
c/o Balmes, 89 - 8^o 2^a
08008 Barcelona SPAIN

Hereby declare that welding equipment:

Power Wave[®] Advanced Module

Product number:

K2912
K4192
(numbers may also contain prefixes and suffixes)

Is in conformity with Council Directives
and amendments:

Electromagnetic Compatibility (EMC) Directive 2014/30/EU

Low Voltage Directive 2014/35/EU

Standards:

EN 60974-1:2012, Arc Welding Equipment – Part 1: Welding
Power Sources

EN 60974-3:2007, Arc Welding Equipment – Part 3: Arc
Striking and Stabilizing Devices

EN 60974-10:2014 Arc Welding Equipment – Part 10:
Electromagnetic compatibility (EMC) requirements

CE marking affixed in:

2014

Handwritten signature of Samir Farah in black ink, written over a horizontal line.

Samir Farah, Manufacturer
Compliance Engineering Manager

Handwritten signature of Jacek Stefaniak in black ink, written over a horizontal line.

Jacek Stefaniak, European Community Representative
European Product Manager Equipment

11 July 2017

19 July 2017

MCD431c



12/05

THANKS! For having chosen the **QUALITY** of the Lincoln Electric products.

- Please Examine Package and Equipment for Damage. Claims for material damaged in shipment must be notified immediately to the dealer.
- For future reference record in the table below your equipment identification information. Model Name, Code & Serial Number can be found on the machine rating plate.

Model Name:	
.....	
Code & Serial number:	
.....
Date & Where Purchased:	
.....

ENGLISH INDEX

Technical Specifications.....	1
Electromagnetic Compatibility (EMC).....	2
Safety	3
Installation and Operator Instructions	4
Spare Parts	29
Authorized Service Shops Location.....	29
Electrical Schematic.....	30
Suggested Accessories.....	31

Technical Specifications

POWER WAVE® ADVANCED MODULE (K2912-1) & ADVANCED MODULE ALUMINUM (K4192-1*)

INPUT VOLTAGE AND CURRENT		
Voltage	Input Amperes	Notes
40Vdc	3.0	
*OUTPUT CURRENT CAPACITY		
Duty Cycle	Amperes	Notes
100%	300	600A Peak (Max.)
40%	350	

* Defines capability of the output switch. the actual output current is supplied by host power source.

PHYSICAL DIMENSIONS			
Height	Width	Depth	Weight
29.2 cm	35.4cm	62.99cm	32.0kg
TEMPERATURE RANGE			
Operating Temperature Range		Storage Temperature Range	
Environmentally Hardened: -4°F to 104°F (-20°C to 40°C)		Environmentally Hardened: -40°F to 185°F (-40°C to 85°C)	

IP23 Insulation Class

Electromagnetic Compatibility (EMC)

01/11

This machine has been designed in accordance with all relevant directives and standards. However, it may still generate electromagnetic disturbances that can affect other systems like telecommunications (telephone, radio, and television) or other safety systems. These disturbances can cause safety problems in the affected systems. Read and understand this section to eliminate or reduce the amount of electromagnetic disturbance generated by this machine.



This machine has been designed to operate in an industrial area. To operate in a domestic area it is necessary to observe particular precautions to eliminate possible electromagnetic disturbances. The operator must install and operate this equipment as described in this manual. If any electromagnetic disturbances are detected the operator must put in place corrective actions to eliminate these disturbances with, if necessary, assistance from Lincoln Electric.

Before installing the machine, the operator must check the work area for any devices that may malfunction because of electromagnetic disturbances. Consider the following.

- Input and output cables, control cables, and telephone cables that are in or adjacent to the work area and the machine.
- Radio and/or television transmitters and receivers. Computers or computer controlled equipment.
- Safety and control equipment for industrial processes. Equipment for calibration and measurement.
- Personal medical devices like pacemakers and hearing aids.
- Check the electromagnetic immunity for equipment operating in or near the work area. The operator must be sure that all equipment in the area is compatible. This may require additional protection measures.
- The dimensions of the work area to consider will depend on the construction of the area and other activities that are taking place.

Consider the following guidelines to reduce electromagnetic emissions from the machine.

- Connect the machine to the input supply according to this manual. If disturbances occur it may be necessary to take additional precautions such as filtering the input supply.
- The output cables should be kept as short as possible and should be positioned together. If possible connect the work piece to ground in order to reduce the electromagnetic emissions. The operator must check that connecting the work piece to ground does not cause problems or unsafe operating conditions for personnel and equipment.
- Shielding of cables in the work area can reduce electromagnetic emissions. This may be necessary for special applications.

WARNING

EMC classification of this product is class A in accordance with electromagnetic compatibility standard EN 60974-10 and therefore the product is designed to be used in an industrial environment only.

WARNING

The Class A equipment is not intended for use in residential locations where the electrical power is provided by the public low-voltage supply system. There can be potential difficulties in ensuring electromagnetic compatibility in those locations, due to conducted as well as radio-frequency disturbances.





The EMC classification of the Power Wave[®] Advanced Module is Industrial, Scientific and Medical (ISM) group 2, class A. The Power Wave[®] Advanced Module is for industrial use only.



WARNING

This equipment must be used by qualified personnel. Be sure that all installation, operation, maintenance and repair procedures are performed only by qualified person. Read and understand this manual before operating this equipment. Failure to follow the instructions in this manual could cause serious personal injury, loss of life, or damage to this equipment. Read and understand the following explanations of the warning symbols. Lincoln Electric is not responsible for damages caused by improper installation, improper care or abnormal operation.

	WARNING: This symbol indicates that instructions must be followed to avoid serious personal injury, loss of life, or damage to this equipment. Protect yourself and others from possible serious injury or death.
	READ AND UNDERSTAND INSTRUCTIONS: Read and understand this manual before operating this equipment. Arc welding can be hazardous. Failure to follow the instructions in this manual could cause serious personal injury, loss of life, or damage to this equipment.
	ELECTRIC SHOCK CAN KILL: Welding equipment generates high voltages. Do not touch the electrode, work clamp, or connected work pieces when this equipment is on. Insulate yourself from the electrode, work clamp, and connected work pieces.
	ELECTRICALLY POWERED EQUIPMENT: Turn off input power using the disconnect switch at the fuse box before working on this equipment. Ground this equipment in accordance with local electrical regulations.
	ELECTRICALLY POWERED EQUIPMENT: Regularly inspect the input, electrode, and work clamp cables. If any insulation damage exists replace the cable immediately. Do not place the electrode holder directly on the welding table or any other surface in contact with the work clamp to avoid the risk of accidental arc ignition.
	ELECTRIC AND MAGNETIC FIELDS MAY BE DANGEROUS: Electric current flowing through any conductor creates electric and magnetic fields (EMF). EMF fields may interfere with some pacemakers, and welders having a pacemaker shall consult their physician before operating this equipment.
	CE COMPLIANCE: This equipment complies with the European Community Directives.
	FUMES AND GASES CAN BE DANGEROUS: Welding may produce fumes and gases hazardous to health. Avoid breathing these fumes and gases. To avoid these dangers the operator must use enough ventilation or exhaust to keep fumes and gases away from the breathing zone.
	ARC RAYS CAN BURN: Use a shield with the proper filter and cover plates to protect your eyes from sparks and the rays of the arc when welding or observing. Use suitable clothing made from durable flame-resistant material to protect you skin and that of your helpers. Protect other nearby personnel with suitable, non-flammable screening and warn them not to watch the arc nor expose themselves to the arc.
	WELDING SPARKS CAN CAUSE FIRE OR EXPLOSION: Remove fire hazards from the welding area and have a fire extinguisher readily available. Welding sparks and hot materials from the welding process can easily go through small cracks and openings to adjacent areas. Do not weld on any tanks, drums, containers, or material until the proper steps have been taken to insure that no flammable or toxic vapors will be present. Never operate this equipment when flammable gases, vapors or liquid combustibles are present.
	WELDED MATERIALS CAN BURN: Welding generates a large amount of heat. Hot surfaces and materials in work area can cause serious burns. Use gloves and pliers when touching or moving materials in the work area.
	SAFETY MARK: This equipment is suitable for supplying power for welding operations carried out in an environment with increased hazard of electric shock.

	<p>CYLINDER MAY EXPLODE IF DAMAGED: Use only compressed gas cylinders containing the correct shielding gas for the process used and properly operating regulators designed for the gas and pressure used. Always keep cylinders in an upright position securely chained to a fixed support. Do not move or transport gas cylinders with the protection cap removed. Do not allow the electrode, electrode holder, work clamp or any other electrically live part to touch a gas cylinder. Gas cylinders must be located away from areas where they may be subjected to physical damage or the welding process including sparks and heat sources.</p>
	<p>MOVING PARTS ARE DANGEROUS: There are moving mechanical parts in this machine, which can cause serious injury. Keep your hands, body and clothing away from those parts during machine starting, operating and servicing.</p>
	<p>EQUIPMENT WEIGHT OVER 30kg: Move this equipment with care and with the help of another person. Lifting may be dangerous for your physical health.</p>

The manufacturer reserves the right to make changes and/or improvements in design without upgrade at the same time the operator's manual.

Installation and Operator Instructions

Read this entire section before installation or operation of the machine.

General Description

The Power Wave® Advanced Module is an accessory enabling compatible power sources to perform the DC+, DC-, AC, STT or any combination of these functions. It is intended for use with medium range “S” – series Power Wave power sources such as the S350 or S500. The Advanced Module will limit the output of an S500 (CE) or R500 to a maximum of 350 amps, regardless of process. The module itself is a low profile pedestal, designed to seamlessly integrate with compatible power sources and water coolers.

Location, Environment and Mounting

(see Figure #1)

Mount the Advanced Module directly to the bottom of a compatible Power Wave® “S” series power source utilizing the quick lock mechanism as shown. The Advanced Module will operate in harsh environments and can be used outdoors. Even so, it is important that simple preventative measures are followed in order to assure long life and reliable operation.

- The machine must be located where there is free circulation of clean air such that movement into and out of the louvers will not be restricted.
- Dirt and dust that can be drawn into the machine should be kept to a minimum. The use of air filters on the air intake is not recommended because normal air flow may be restricted. Failure to observe these precautions can result in excessive operating temperatures and nuisance shutdown.
- Keep the machine dry. Shelter from rain and snow. Do not place on wet ground or in puddles.
- Do not mount the Power Wave® “S” series power source and Advanced Module combination over combustible surfaces. Where there is a combustible surface directly under stationary or fixed electrical equipment, that surface shall be covered with a steel plate at least 1.6mm thick, which shall extend not less than 150mm beyond the equipment on all sides.

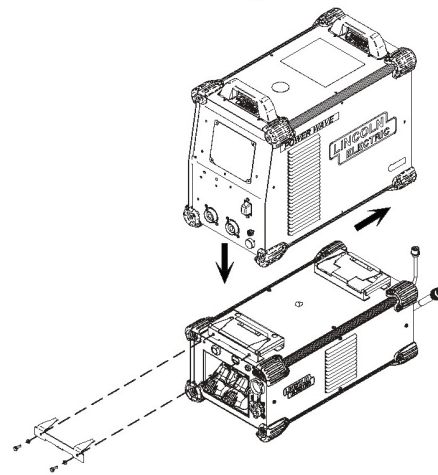
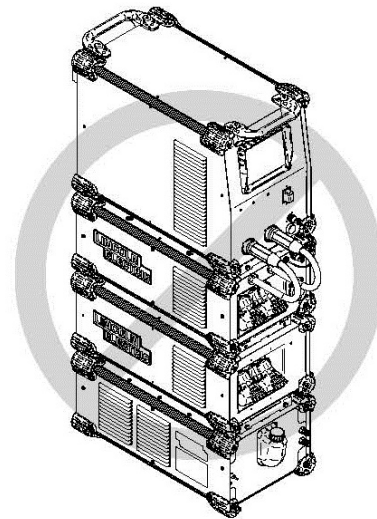

Figure #1



STACK HEIGHT NOT TO EXCEED ONE POWER SOURCE AND TWO MODULES.

Figure #2

Machine Grounding and High Frequency Interference Protection

The host power source must be earth grounded! See your local and national electrical codes for proper grounding methods.

The Advanced Module utilizes a high frequency impulse to initiate the arc of selected GTAW (TIG) welding procedures. Although the power of this impulse is significantly less than traditional arc stabilization circuits, it is best to locate the power source and Advanced Module away from radio controlled machinery as it may adversely affect the operation of the RF controlled equipment, which may result in bodily injury or damage to the equipment.

The high frequency starting impulse may also cause radio, TV and electronic equipment interference problems. These problems may be the result of radiated interference. Proper grounding methods can reduce or eliminate radiated interference.

Radiated interference can develop in the following four ways:

1. Direct interference radiated from the welder.
2. Direct interference radiated from the welding leads.
3. Direct interference radiated from feedback into the power lines.
4. Interference from re-radiation of "pickup" by ungrounded metallic objects.

Keeping these contributing factors in mind, installing equipment per the following instructions should minimize problems.

1. Keep the welder power supply lines as short as possible and enclose as much of them as possible in rigid metallic conduit or equivalent shielding for a distance of 50 feet (15.2m). There should be good electrical contact between this conduit and the welder case ground. Both ends of the conduit should be connected to a driven ground and the entire length should be continuous.
2. Keep the work and electrode leads as short as possible and as close together as possible. Lengths should not exceed 7.6m. Tape the leads together when practical.
3. Be sure the torch and work cable rubber coverings are free of cuts and cracks that allow high frequency leakage.
4. Keep the torch in good repair and all connections tight to reduce high frequency leakage.
5. The work piece must be connected to an earth ground close to the work clamp, using one of the following methods:
 - A metal underground water pipe in direct contact with the earth for ten feet or more.
 - A 19mm galvanized pipe or a 16mm solid galvanized iron, steel or copper rod driven at least eight feet into the ground.

The ground should be securely made and the grounding cable should be as short as possible using cable of the same size as the work cable, or larger. Grounding to the building frame electrical conduit or along pipe system can result in re-radiation, effectively making these members radiating antennas.

6. Keep cover and all screws securely in place.
7. Electrical conductors within 15.2m of the welder should be enclosed in grounded rigid metallic conduit or equivalent shielding, wherever possible. Flexible metallic conduit is generally not suitable.
8. When the welder is enclosed in a metal building, the metal building should be connected to several good earth driven electrical grounds around the periphery of the building.

Failure to observe these recommended installation procedures can cause radio or TV and electronic equipment interference problems and result in unsatisfactory welding performance resulting from lost high frequency power.

Stacking

Stacking of the Power Wave® Advanced Module shall not exceed a power source above and one module below.

Duty Cycle

The Advanced Module is rated at 300 amps at a 100% duty cycle. It is further rated to support 350 amps at 40% duty cycle. The duty cycle is based on 10 minute period. A 40% duty cycle represents 4 minutes of welding and 6 minutes of idling in a ten-minute period.

Note: the Advanced Module is capable of withstanding a peak output current of 600 amps. The allowable maximum average output current is time dependant, and ultimately limited by the host power source.

Example: 40% Duty Cycle:

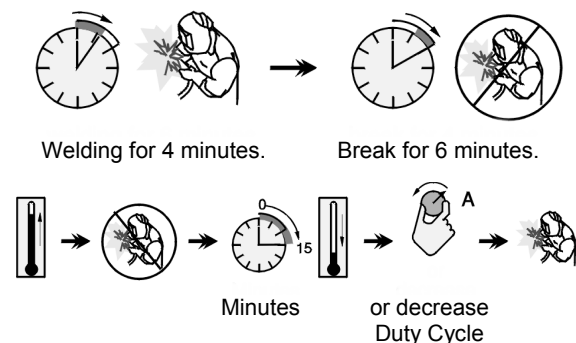

Control Cable Connections

General guidelines

Genuine Lincoln control cables should be used at all times (except where noted otherwise). Lincoln cables are specifically designed for the communication and power needs of the Power Wave® systems. Most are designed to be connected end to end for ease of extension. Generally, it is recommended that the total length not exceed 30.5 m. The use of non-standard cables, especially in lengths greater than 25 feet, can lead to communication problems (system shutdowns), poor motor acceleration (poor arc starting), and low wire driving force (wire feeding problems). Always use the shortest length of control cable possible, and DO NOT coil excess cable.

⚠ WARNING

Regarding cable placement, best results will be obtained when control cables are routed separate from the weld cables. This minimizes the possibility of interference

between the high currents flowing through the weld cables, and the low level signals in the control cables. These recommendations apply to all communication cables including ArcLink® connections.

Special Considerations for High Frequency GTAW (TIG) Welding

Although the equipment has been designed to withstand the high frequency starting impulse, special care should be taken to isolate this energy from the control signals of the welding system and other equipment. The following guidelines apply:

- Follow the recommendations in the **Machine Grounding and High Frequency Interference Protection** section of this document.
- Locate the control cables and adjacent equipment away from the weld cables and TIG torch.
- Consider optical isolation for critical applications via the Ethernet interface on the power source (such as ArcLink XT, Production Monitoring, etc.). Ethernet to fiber media converters are commercially available, and will significantly improve the electrical and magnetic interference immunity of these signals.

Connection between Power Source and Advanced Module (Arclink®, Voltage Sense and Differential I/O Pigtails)

The pigtail connections on the Advanced Module include all signal and power lines required for proper operation. With the Advanced Module securely fastened to the power source, connect the pigtails to their respective receptacles on the back and front of the power source per the connection diagrams located in this document.

Arclink Pigtail (5 pin)

Provides power to the Advanced Module as well as a digital link for system information.

Voltage Sense Pigtail (4 pin)

Provides accurate voltage feedback to the power source from either the output studs of the module or remote sense lead locations based on the process.

Differential I/O Pigtail (6 pin)

Provides high speed control signals for polarity and STT function.

Special Instructions

CE machines:

A special ArcLink® and Differential I/O receptacle kit is provided with the Advanced Module CE Kit (K3980-1) for installation into the host power source. Follow the instructions provided with the kit. (reference instruction sheet M22499)

Power Wave S350 (Code 11589)

Some earlier vintage S350 power sources may not include a 6 pin Differential I/O receptacle. If the receptacle is not present on the host power source, contact the Lincoln Electric Service Department to obtain an S350/STT Retrofit Kit (S28481).

Connection between Power Source and Advanced Module to Arclink® wire feeders (K1543 or K2683 Arclink®)

Control Cable)

The K2912-1 Advanced Module includes an ArcLink® output receptacle for connection to compatible wire feeders. The 5 pin ArcLink® receptacle is located on the lower rear portion of the Advanced Module. The control cable is keyed and polarized to prevent improper connection.

Best results will be obtained when control cables are routed separate from the weld cables, especially in long distance applications. The recommended combined length of the ArcLink® control cable network should not exceed 200ft.

CE machines:

S350 and S500 CE Power Source have an ArcLink output receptacle located on the case front. The ArcLink wire feeder can be attached to either the receptacle on the power source case front or Advanced Module case back.

Electrode and Work Connections

Connect the positive and negative input connections and electrode and work output cables per the connection diagrams included in this document. Size and route the cables per Table 1.

- Wire feeders should always be connected to the GMAW electrode stud.
- TIG (GTAW) torches and Stick (SMAW) holders should always be connected to the GTAW/SMAW electrode.
- The workpiece should always be connected to the work stud.
- The output polarity is automatically configured based on the selected weld mode. There is no need to reverse the output cables.

WARNING

Never reverse the polarity at the input of the Advanced Module (DO NOT connect the negative stud of the power source to the positive input of the Advanced Module). Although this will not damage the Advanced Module, it will prevent welding output.

For additional Safety information regarding the electrode and work cable set-up, See the standard "SAFETY INFORMATION" located in the front of the Instruction Manuals.

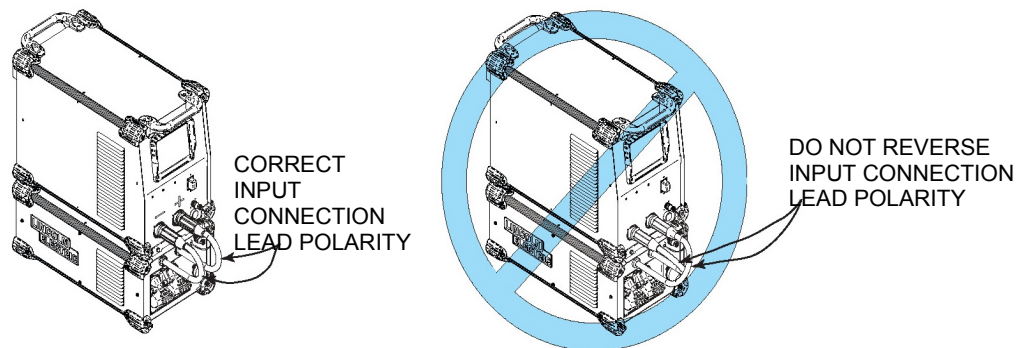

Figure #3: Correct Polarity

Table 1

OUTPUT CABLE GUIDELINES						
AMPERES	PERCENT DUTY CYCLE	CABLE SIZES FOR COMBINED LENGTHS OF ELECTRODE AND WORK CABLES (RUBBER COVERED COPPER – RATED 75#C)**				
		0 to 15m	15 to 30m	30 to 46m	46 to 61m	61 to 76m
200	60	35mm ²	35mm ²	35mm ²	50mm ²	70mm ²
200	100	35mm ²	35mm ²	35mm ²	50mm ²	70mm ²
225	20	25mm ²	35mm ²	25mm ²	50mm ²	70mm ²
225	40 & 30	35mm ²	35mm ²	35mm ²	50mm ²	70mm ²
250	30	35mm ²	35mm ²	35mm ²	50mm ²	70mm ²
250	40	35mm ²	35mm ²	50mm ²	50mm ²	70mm ²
250	60	50mm ²	50mm ²	50mm ²	50mm ²	70mm ²
250	100	50mm ²	50mm ²	50mm ²	50mm ²	70mm ²
300	60	50mm ²	50mm ²	50mm ²	70mm ²	70mm ²
350	100	70mm ²	70mm ²	70mm ²	70mm ²	95mm ²
350	60	70mm ²	70mm ²	70mm ²	70mm ²	95mm ²
400	60	70mm ²	70mm ²	70mm ²	95mm ²	120mm ²
400	100	70mm ²	95mm ²	95mm ²	95mm ²	120mm ²
500	60	70mm ²	70mm ²	95mm ²	95mm ²	120mm ²

** Tabled values are for operation at ambient temperatures of 104°F(40°C) and below. Applications above 104°F(40°C) may require cables larger than recommended, or cables rated higher than 167°F(75°C).

Figure #4

General Guidelines

Select the appropriate size cables per the “Output Cable Guidelines” (See Table 1). Excessive voltage drops caused by undersized welding cables and poor connections often result in unsatisfactory welding performance. Always use the largest welding cables (electrode and work) that are practical, and be sure all connections are clean and tight.

Note: Excessive heat in the weld circuit indicates undersized cables and/or bad connections.

- Route all cables directly to the work and wire feeder, avoid excessive lengths and do not coil excess cable. Route the electrode and work cables in close proximity to one another to minimize the loop area and therefore the inductance of the weld circuit.
- Always weld in a direction away from the work (ground) connection.

See Table 1 for copper cable sizes recommended for different currents and duty cycles. Lengths stipulated are the distance from the welder to work and back to the welder again. Cable sizes are increased for greater lengths primarily for the purpose of minimizing cable drop.

Cable Inductance and its Effects on Welding

Excessive cable inductance will cause the welding performance to degrade. There are several factors that contribute to the overall inductance of the cabling system including cable size, and loop area. The loop area is defined by the separation distance between the electrode and work cables, and the overall welding loop length. The welding loop length is defined as the total of length of the electrode cable (A) + work cable (B) + work path (C) (see Figure #4 below). To minimize inductance always use the appropriate size cables, and whenever possible, run the electrode and work cables in close proximity to one another to minimize the loop area. Since the most significant factor in cable inductance is the welding loop length, avoid excessive lengths and do not coil excess cable. For long work piece lengths, a sliding ground should be considered to keep the total welding loop length as short as possible.

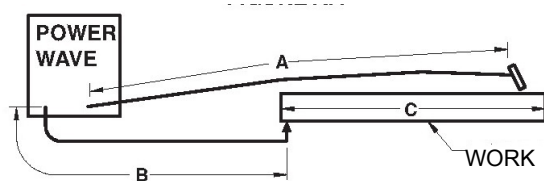

Remote Sense Lead Connections

Voltage Sensing Overview

Certain welding process requires the use of remote voltage sense leads to more accurately monitor the conditions of the arc. These leads originate in the power source, and are connected and configured through the Advanced Module. Consult the connection diagrams included in this manual for detailed information.

Note:

Not all processes run through the Advanced Module do not necessarily require sense leads, but will benefit from their use. Consult the power source instruction manual for recommendations.

⚠ WARNING

DO NOT connect the remote electrode sense (67) lead to the TIG (GTAW) output.

General Voltage Sensing Considerations for Multiple Arc Systems

Special care must be taken when more than one arc is welding simultaneously on a single part. The placement and configuration of remote work voltage sense leads is critical to the proper operation of multiple arc AC and STT[®] applications.

Recommendations:

- **Position the sense leads out of the path of the weld current.** Especially any current paths common to adjacent arcs. Current from adjacent arcs can induce voltage into each others current paths that can be misinterpreted by the power sources, and result in arc interference.
- **For longitudinal applications,** connect all work leads at one end of the weldment, and all of the work voltage sense leads at the opposite end of the weldment. Perform welding in the direction away from the work leads and toward the sense leads. (See Figure #5).

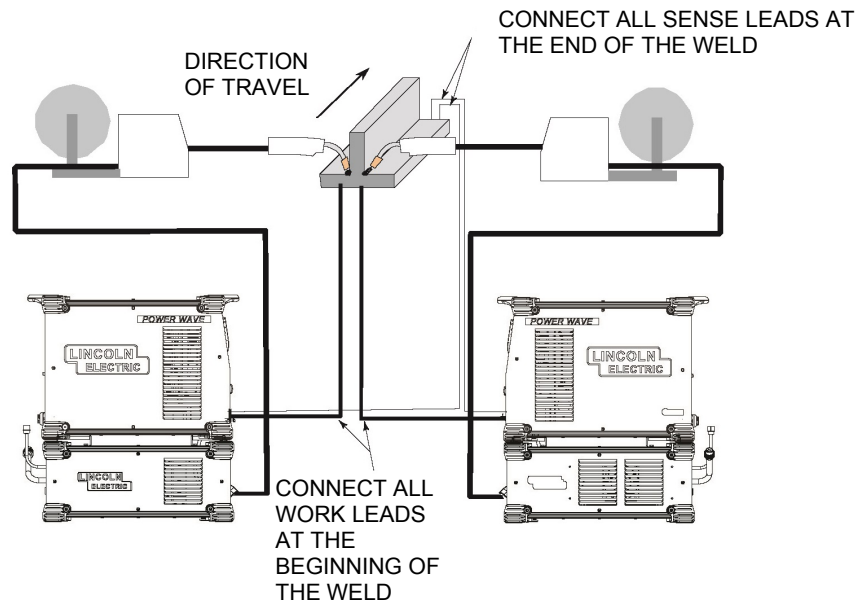
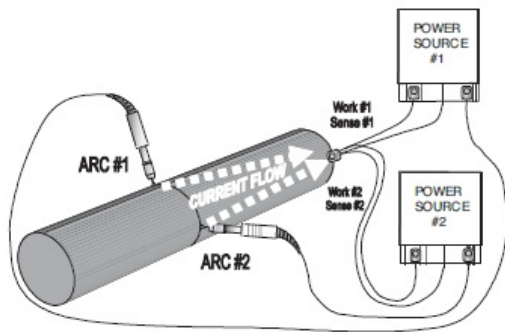

Figure #5

For circumferential applications, connect all work leads on one side of the weld joint, and all of the work voltage sense leads on the opposite side, such that they are out of the current path.

Bad connection



- Current flow from **Arc#1** affects **Sense lead #2**.
- Current flow from **Arc#2** affects **Sense lead #1**.
- Neither sense lead picks up the correct work voltage, causing starting and welding arc instability.

Better connection

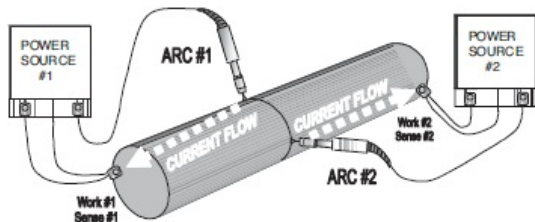

- **Sense lead #1** is only affected by current flow from **Arc#1**.
- **Sense lead #2** is only affected by current flow from **Arc#2**.
- Due to voltage drops across workpiece, Arc voltage may be low, causing need for deviation from standard procedures.

Best connection

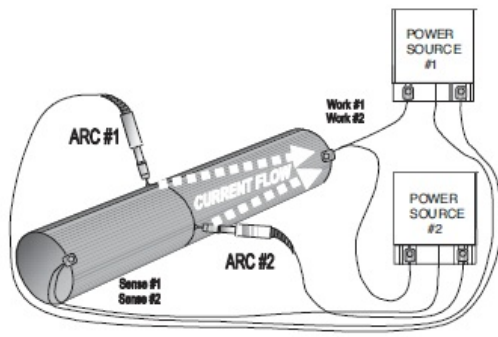

- Both **Sense** leads are out of the current paths.
- Both **Sense** leads detect arc voltage accurately.
- No voltage drop between **Arc** and **Sense** leads.
- Best start, best arcs, most reliable results.
- **For circumferential applications**, connect all work leads on one side of the weld joint, and all of the work voltage sense leads on the opposite side, such that they are out of the current path.

Power Wave® S350 CE or S500 CE GMAW Connection Diagrams

Figure #6.

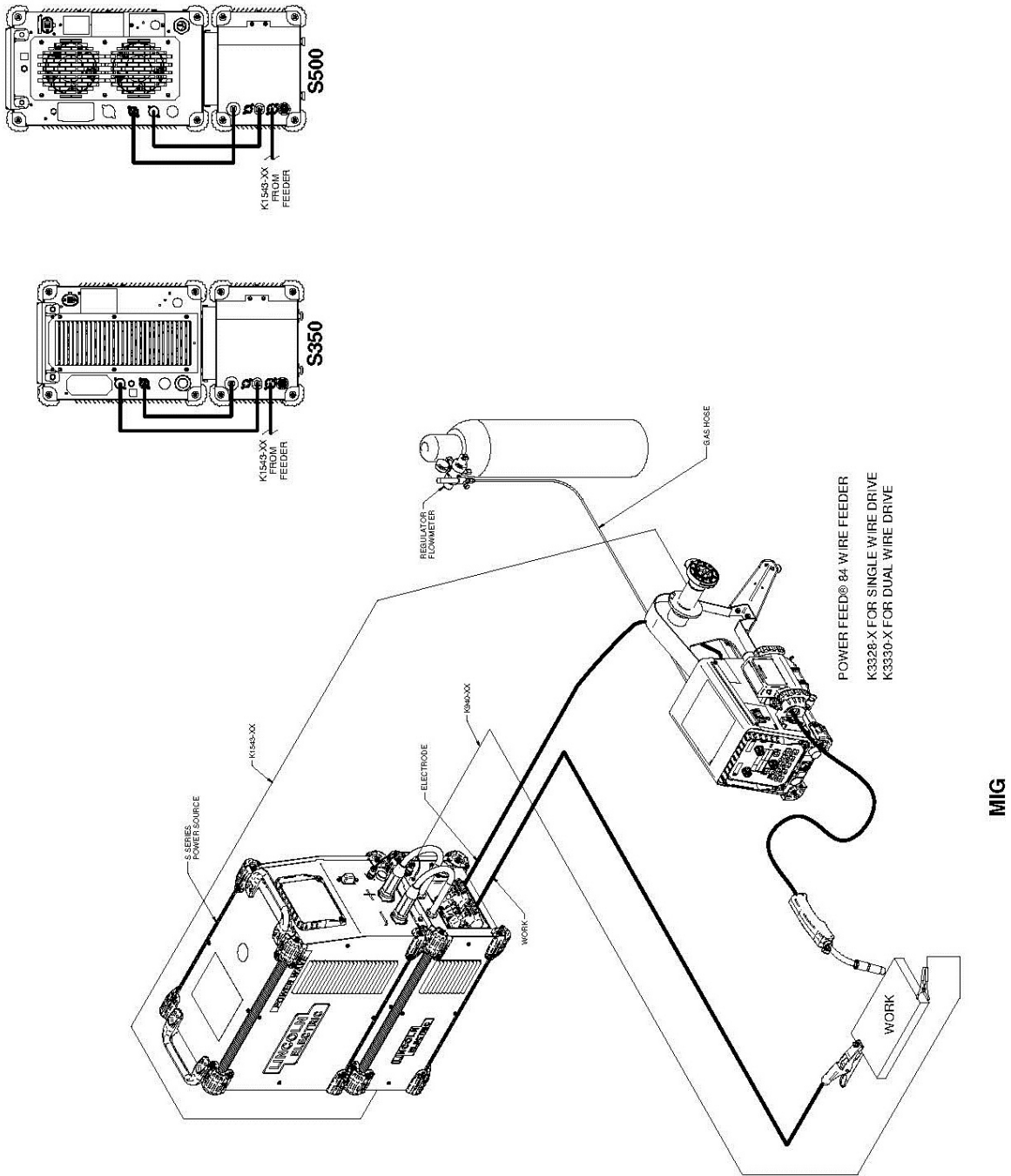

Power Wave® S350 CE or S500 Cool Arc 55S Cooled Push-Pull Gun GMAW Connection Diagrams

Figure #7.

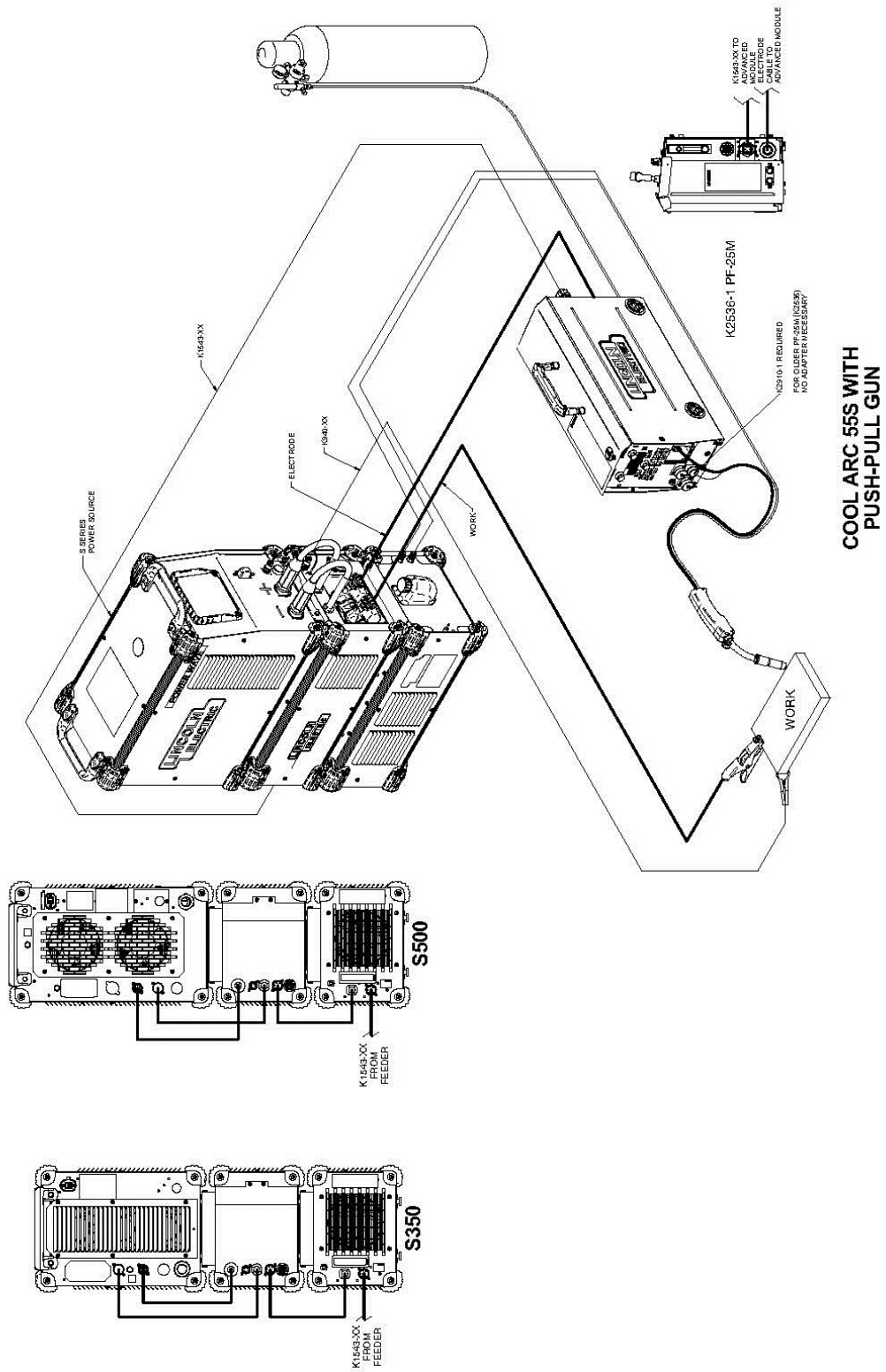

Power Wave[®] S350 CE or S500 with User Interface Kit GTAW Connection Diagrams
 Figure #8.

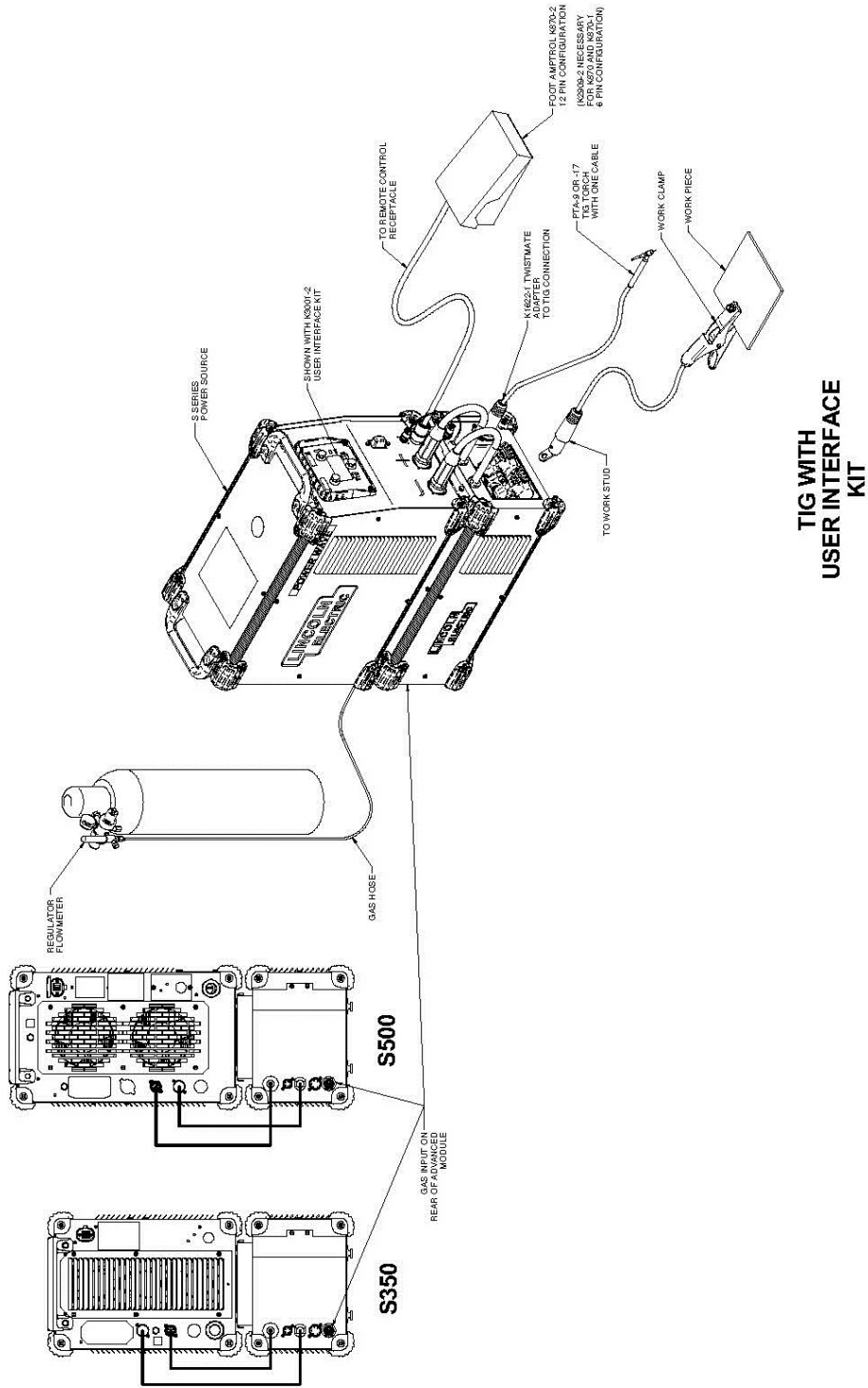

NOTE:
 THE PTA-26 AND -17 TIG TORCHES WITH TWO CABLES CAN BE USED
 WITH K1622-3 ADAPTER, BUT THEY WILL NOT PROVIDE HIGH
 FREQUENCY STARTING.

Power Wave® S350 CE or S500 GTAW Connection Diagrams

Figure #9.

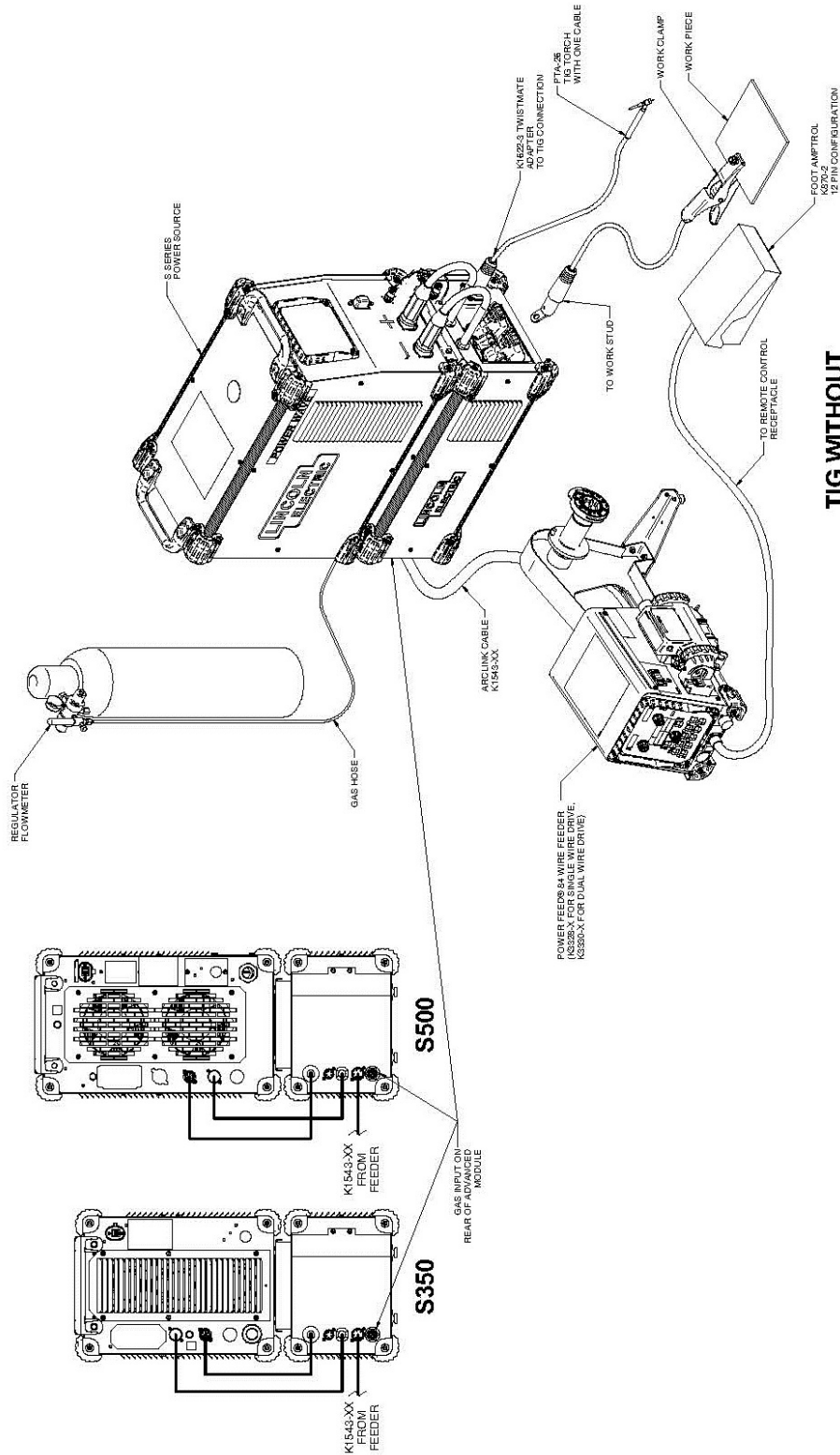

TIG WITHOUT USER INTERFACE KIT

NOTE:
THE PTA-25 AND -17 TIG TORCHES WITH TWO CABLES CAN BE USED WITH THE S3-DAPTER, BUT THEY WILL NOT PROVIDE HIGH FREQUENCY STARTING.

Power Wave® S350 CE or S500 with Cool Arc 55S and Water Cooled Torch GTAW Connection Diagrams

Figure #10.

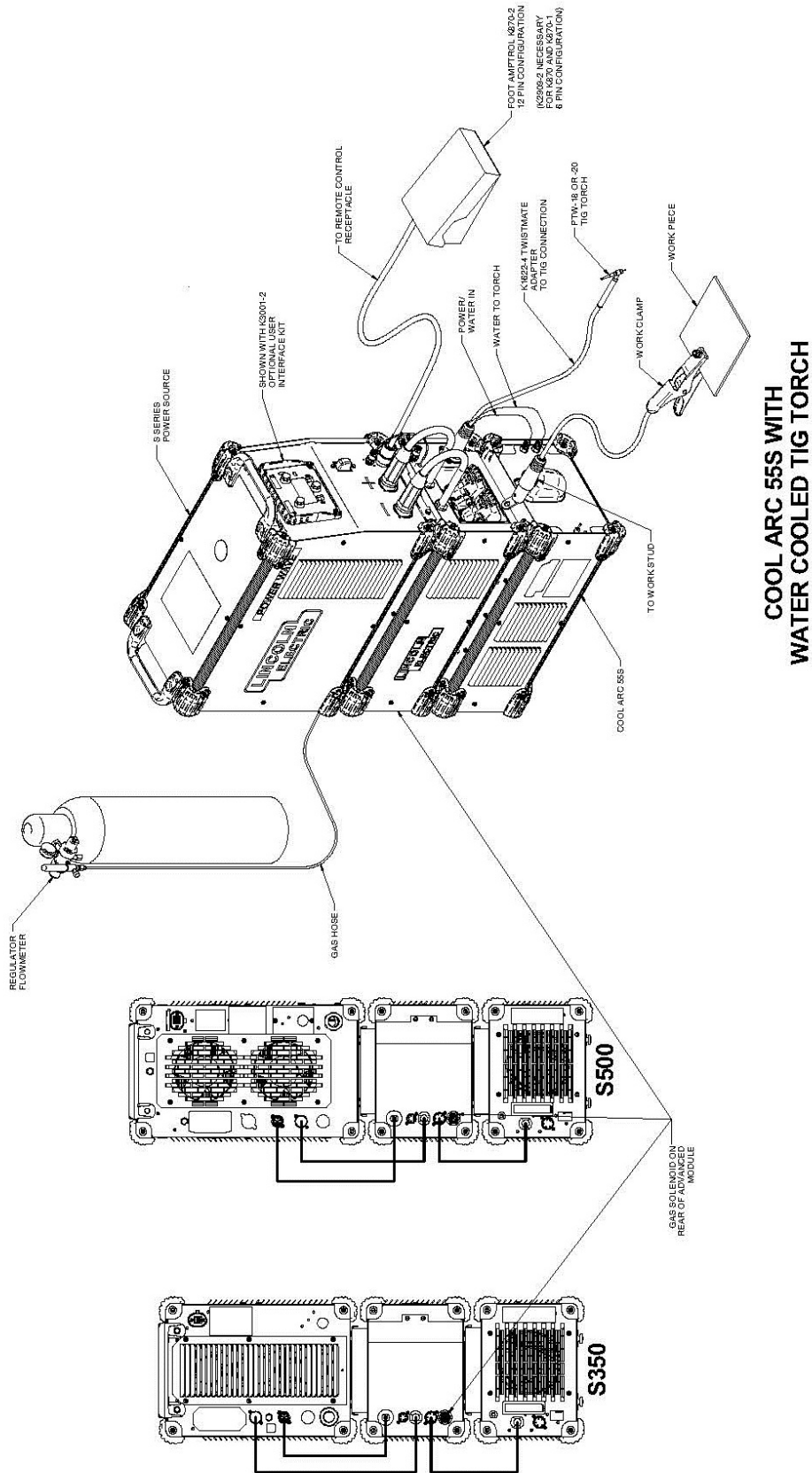

**COOL ARC 55S WITH
WATER COOLED TIG TORCH**

Power Wave® S350 CE or S500 Robotic Connection Diagrams

Figure #11.

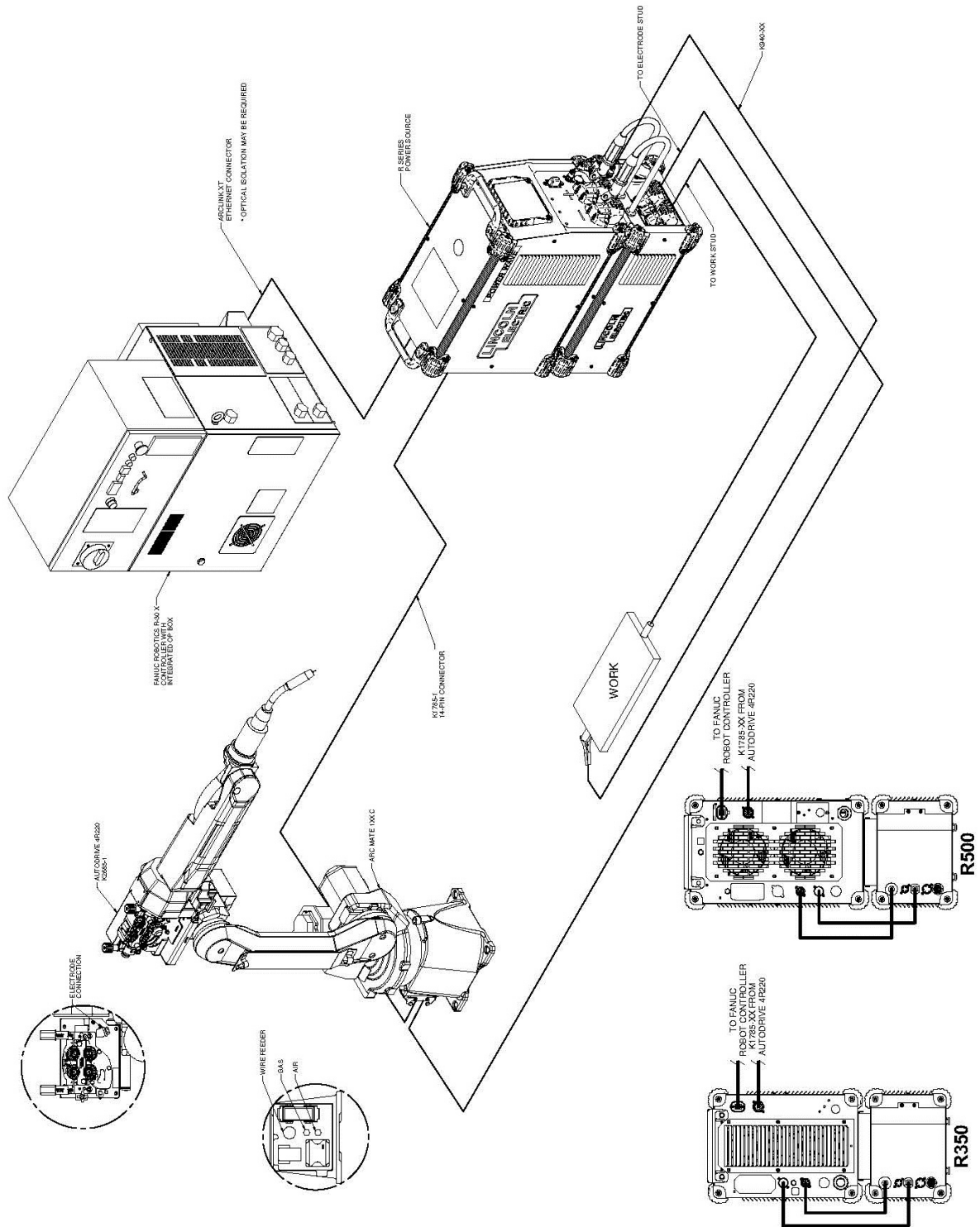

Power Wave® S350 CE or S500 with User Interface Kit SMAW Connection Diagrams
 Figure #12.

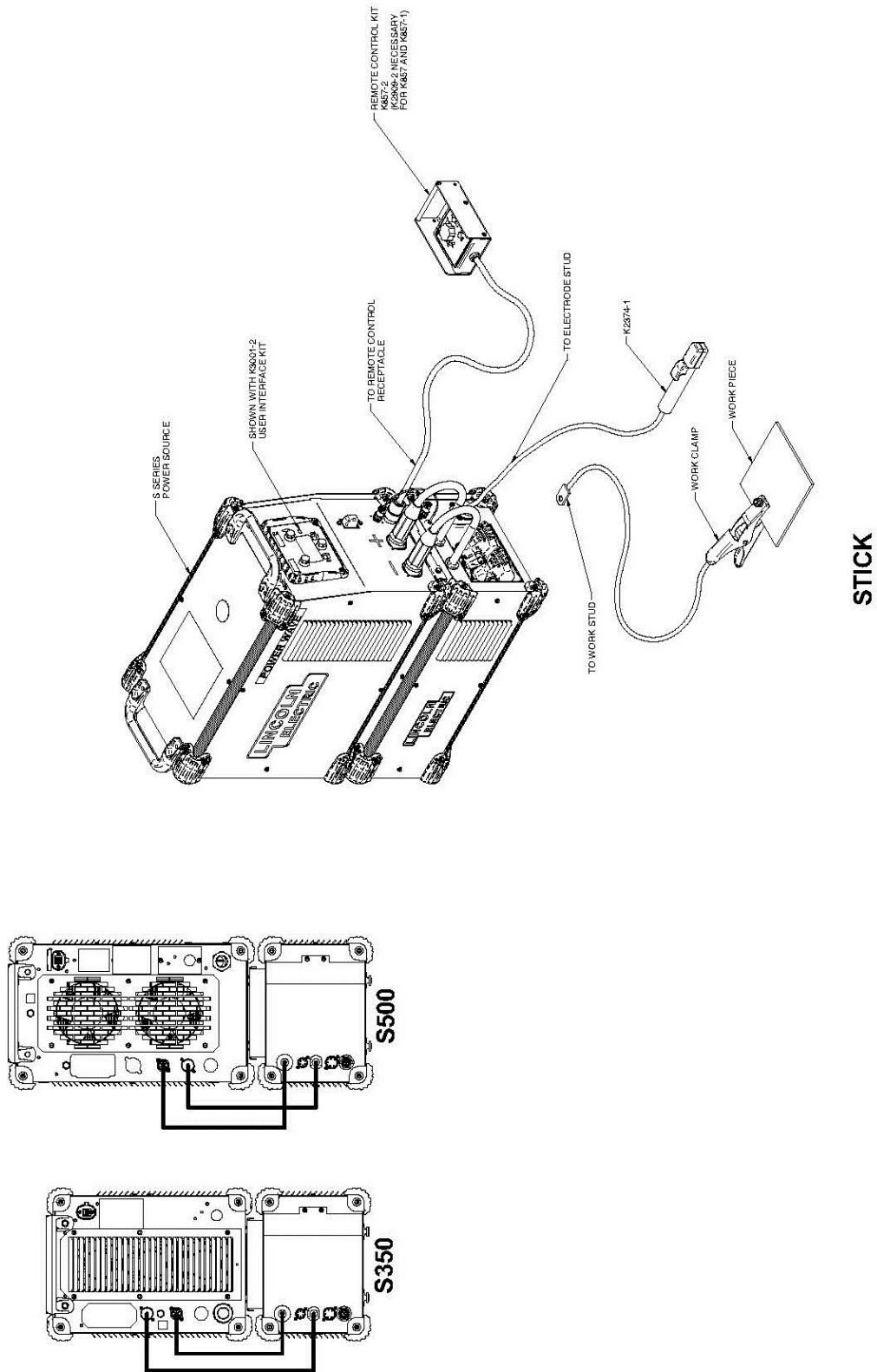

Power Wave[®] S350 CE or S500 CE GMAW Connection Diagrams

Figure #13.

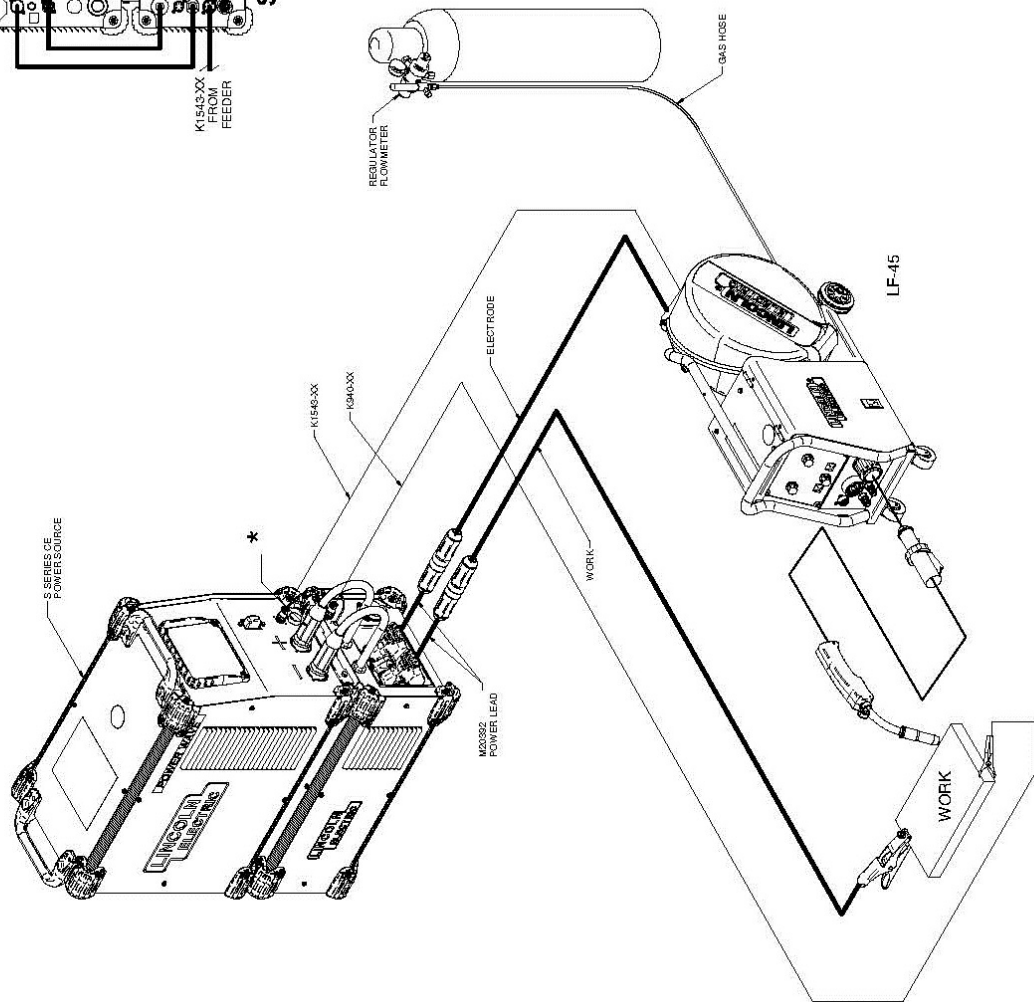
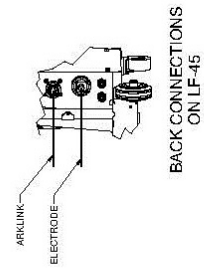
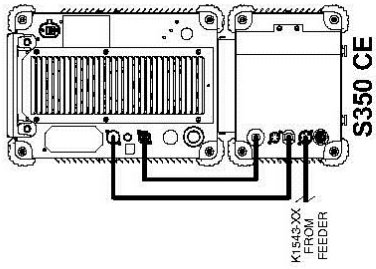
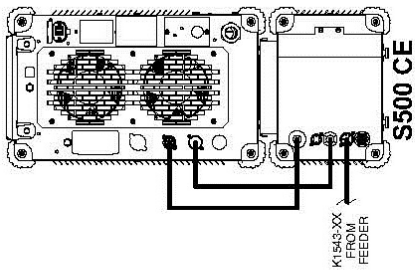

Power Wave® S350 CE or S500 CE with Cool Arc 50 Water Cooled Push-Pull Gun

GMAW Connection Diagrams

Figure #14.

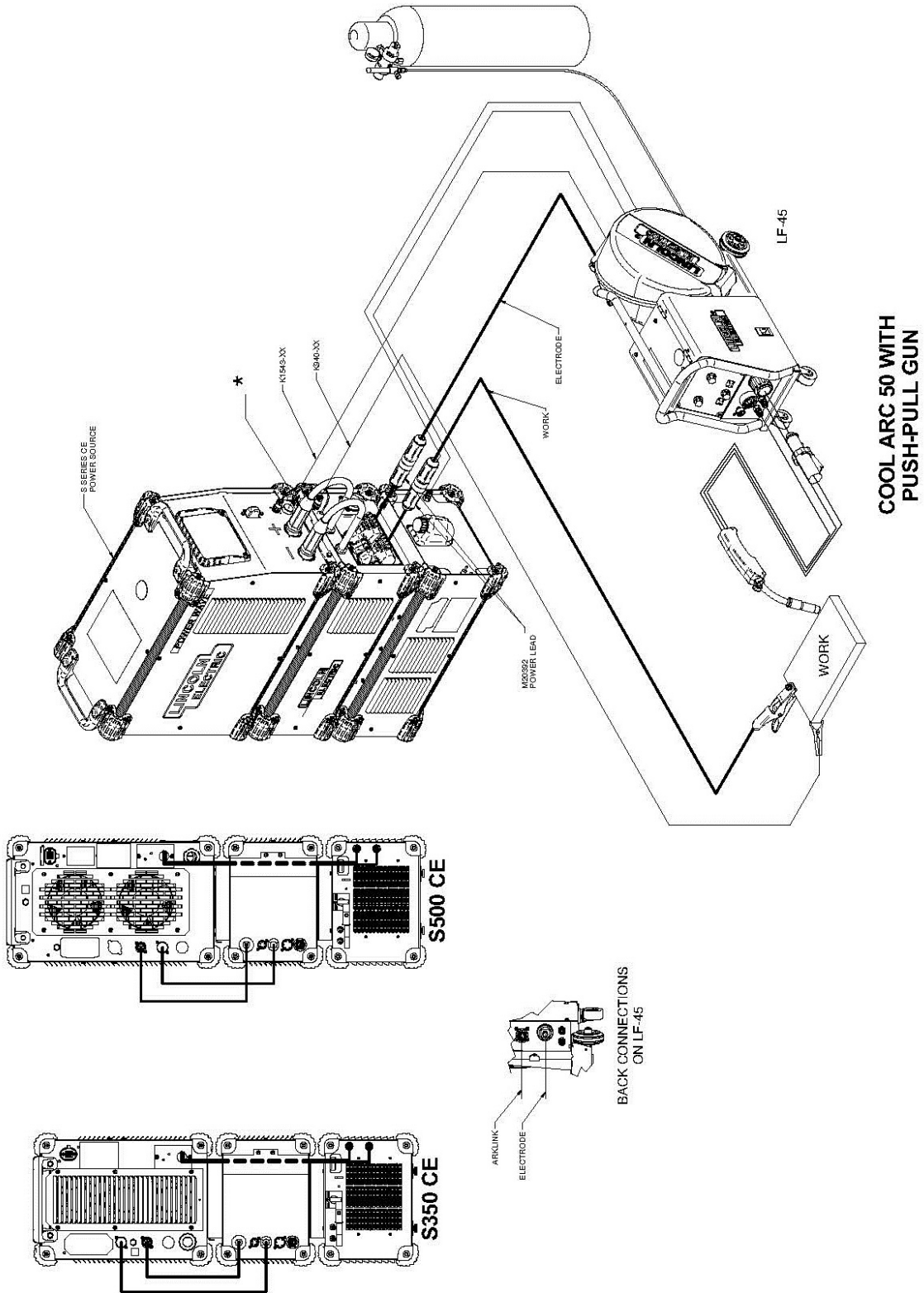

Power Wave® S500 (only) with User Interface GTAW Connection Diagrams
 Figure #15.

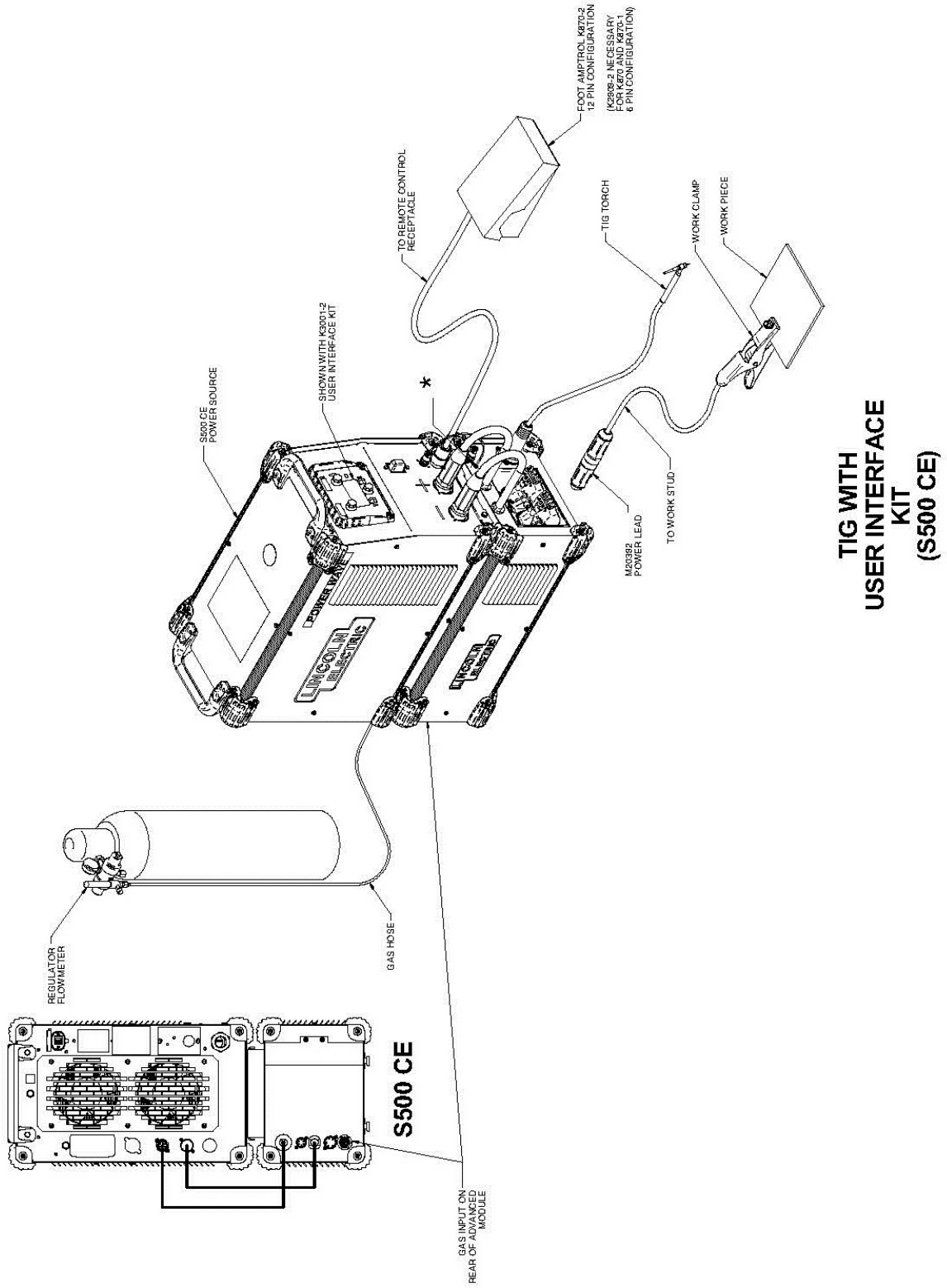

Power Wave® S350 CE or S500 CE GTAW Connection Diagrams

Figure #16.

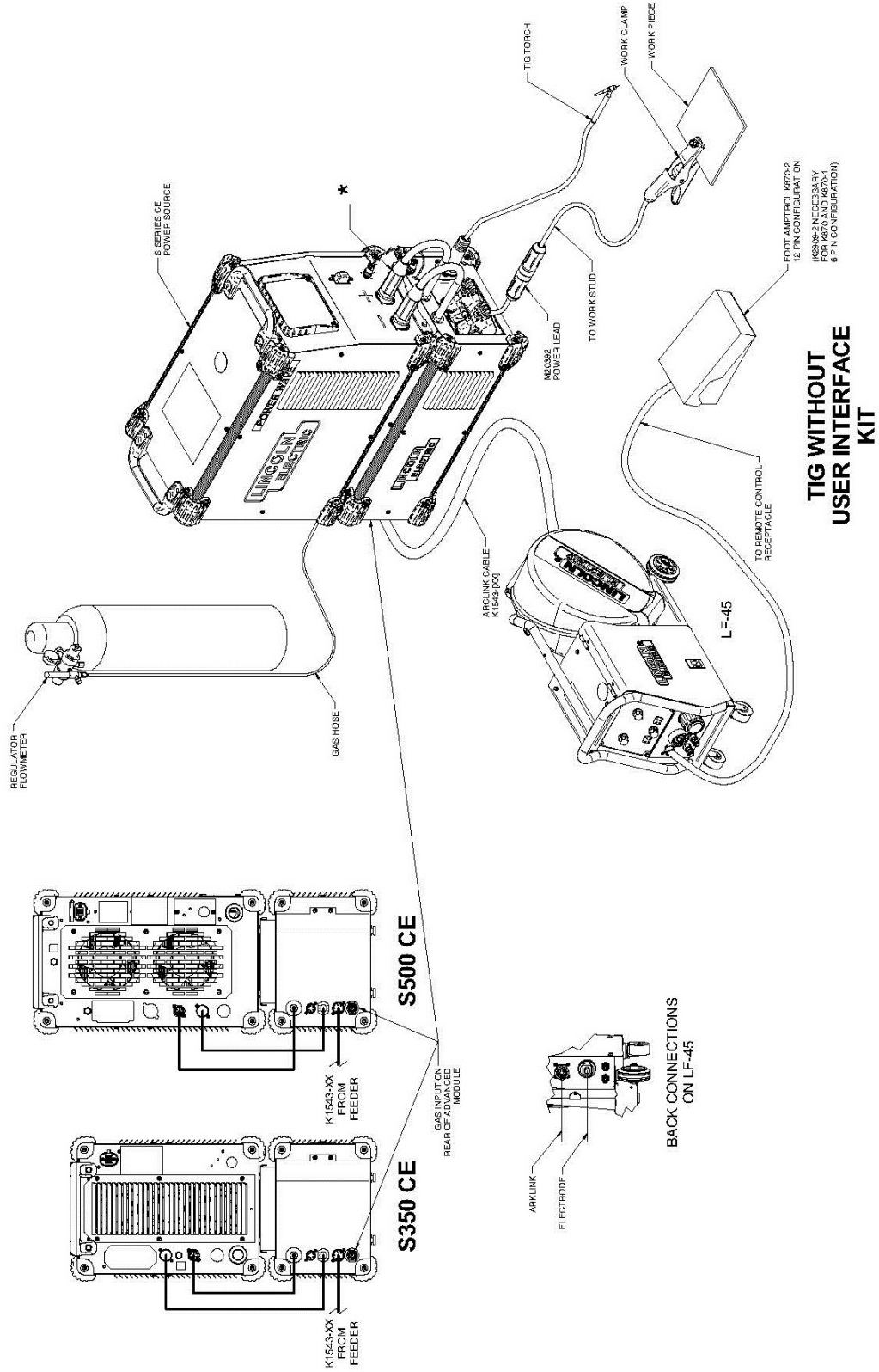

Power Wave® S500 CE (only) with User Interface Kit Cool Arc 50 and Water Cooled Torch
Figure #17.

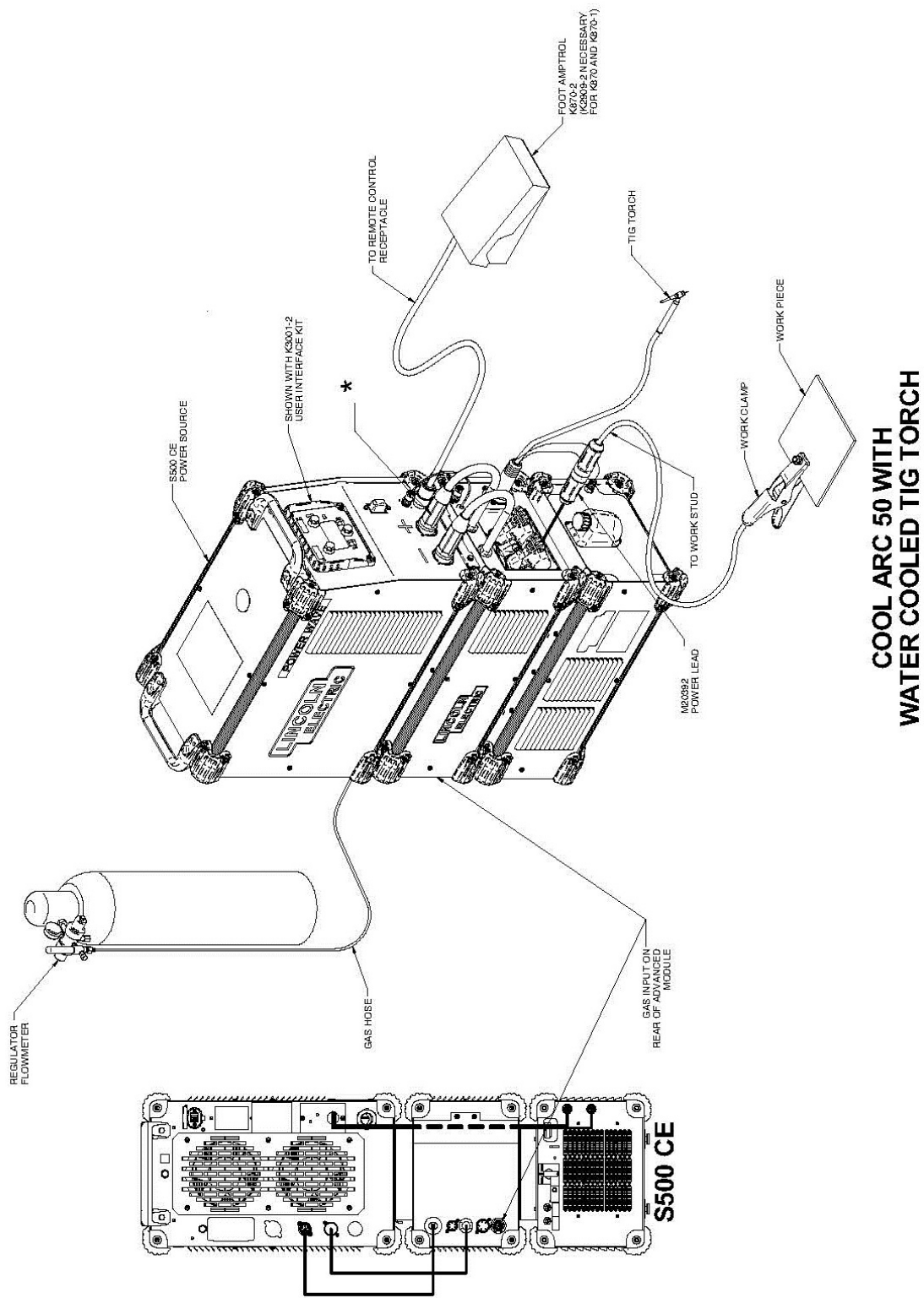

COOL ARC 50 WITH WATER COOLED TIG TORCH

Power Wave[®] S350 CE or S500 CE with Autodrive 19 Robotic Connection Diagrams
 Figure #18.

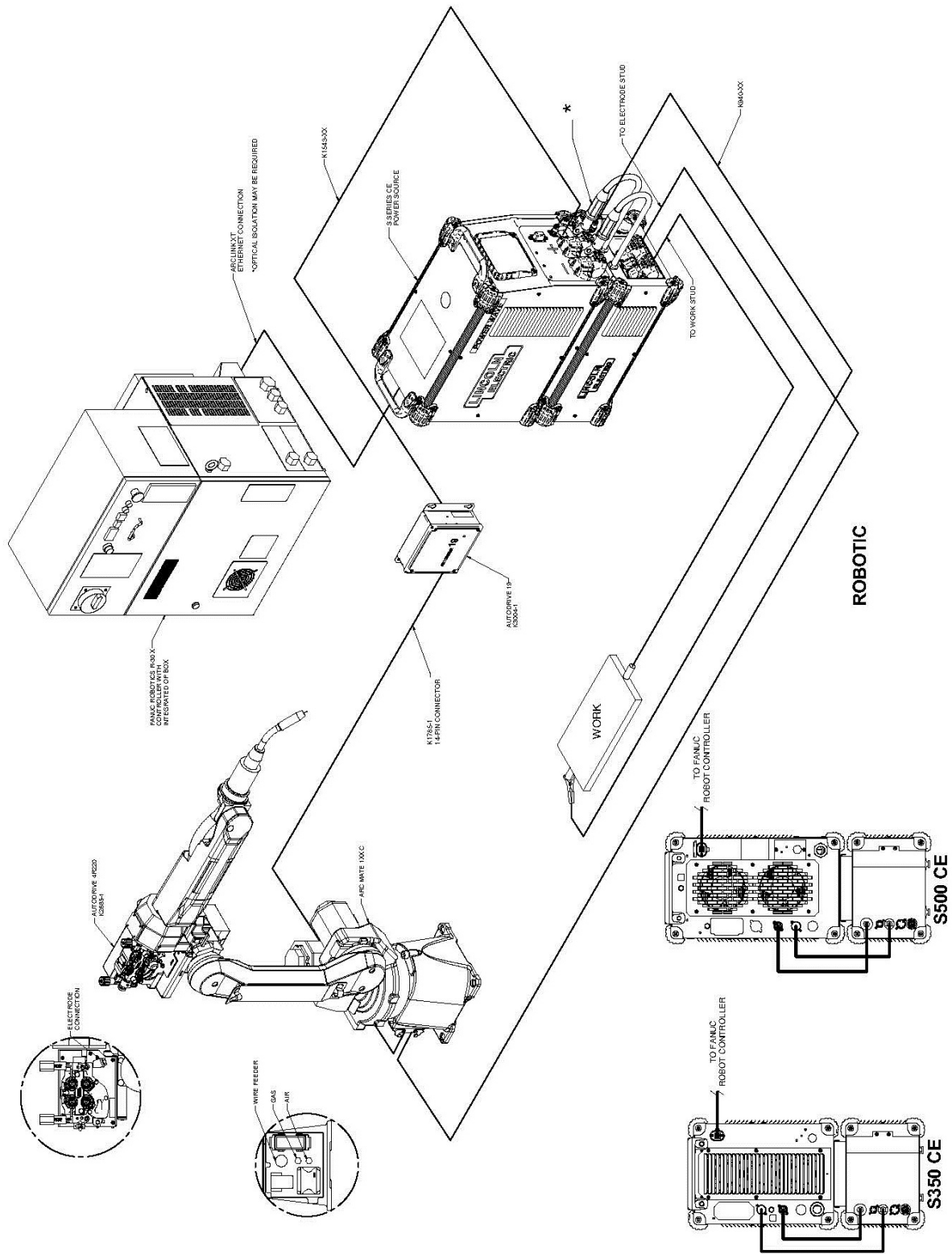

Power Wave® S500 CE (only) with User Interface Kit SMAW Connection Diagrams
 Figure #19.

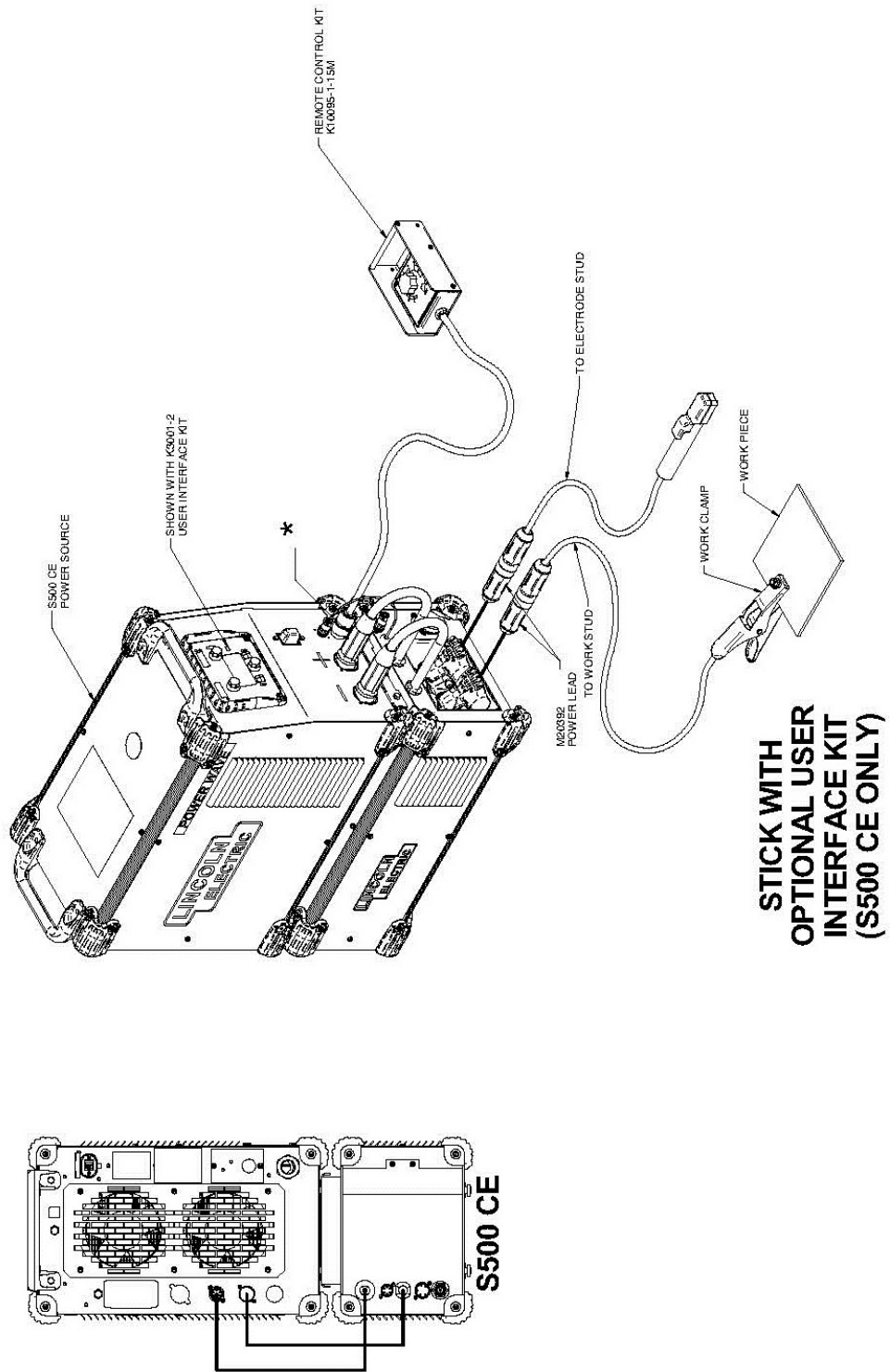

Power Wave[®] S350 CE or S500 CE SMAW Connection Diagrams

Figure #20.

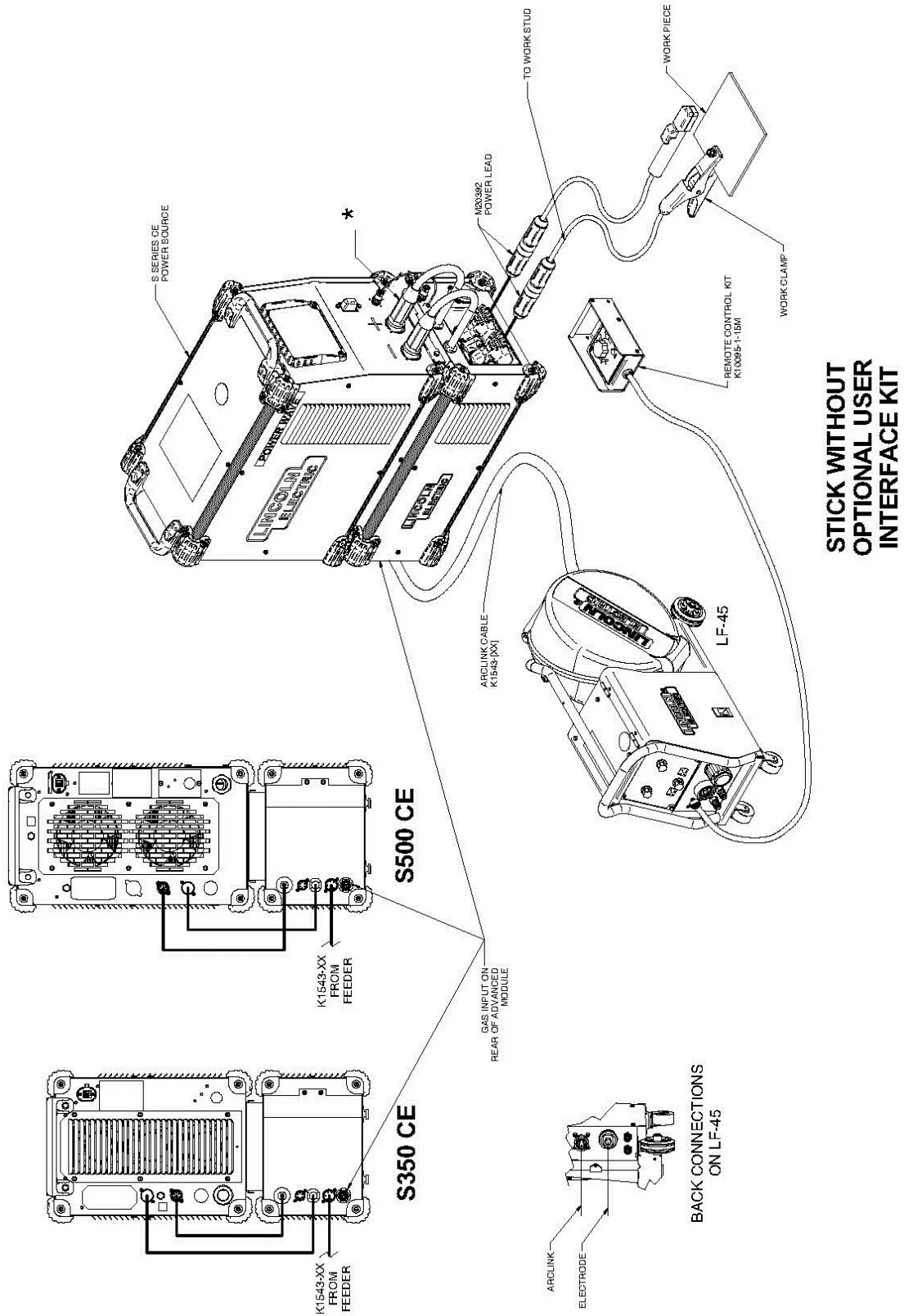

Power-up Sequence

The Advanced Module will be powered up at the same time as the power source. The status light will blink green for about a minute while the system is configuring. After this time, the status lights will turn a steady green indicating the machine is ready.

The fan in the Advanced Module will run when the output is enabled and for 5 minutes after the output is disabled. The speed of the fan is dependent upon the work point. The speed of the fan prior to the output being disabled will be maintained for the 5 minutes.

Common Welding Procedures

Making a weld

Select the weld mode that best matches the desired welding process. The standard weld set shipped with the host power source encompasses a wide range of common processes that will meet most needs. If the AC or STT modes are not available, visit www.powerwavesoftware.com or contact the local Lincoln Electric sales representative.

Certain welding processes require a reversed output polarity. The Advanced Module will recognize the specific weld modes and automatically reconfigure the output polarity. No change needs to be made to output cable connections.

For a more detailed descriptor, and specific operating instructions, consult the power source and or feeder instruction manual.

For specific operating instructions consult the power source and feeder instruction manuals. For a detailed description of available welding modes, visit www.powerwavesoftware.com.

Product Description

The Power Wave® Advanced Module is recommended for all process supported by the host power source including, but not limited to SMAW, GMAW, GMAW-P, GMAW-STT, GTAW.

Process Limitations

The Advanced Module is rated for 300 amps, 32 volts at a 100% duty cycle and 350 amps, 34 volts at a 40% duty cycle rating. When connected to an S500 (CE) power source, the power source will acknowledge that the Advanced module is connected and reduce the output capability to match that of the S350(CE).

Equipment Limitations

The Power Wave® Advanced Module is intended for use with compatible medium range “S” – series Power Wave power sources such as the S350 and S500

Special Information regarding Ac-Welding

The AC output capability of the Advanced Module combined with the flexibility of Waveform Control Technology™ enables a nearly infinite combination of output waveforms. The AC waveform Frequency, Wave Balance and Offset can now be utilized to further optimize the characteristics of a given arc. For a complete description of how these variables are used to adjust the arc performance characteristics of a specific weld mode visit www.powerwavesoftware.com

Frequency

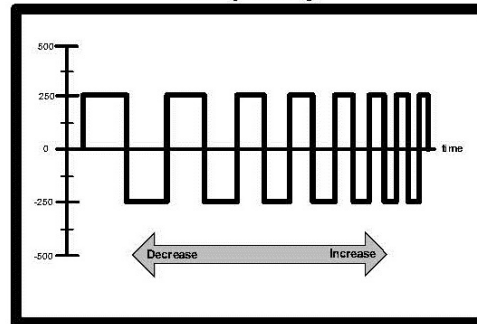

Wave Balance

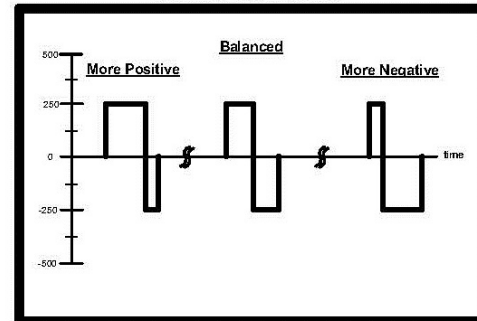

DC Offset

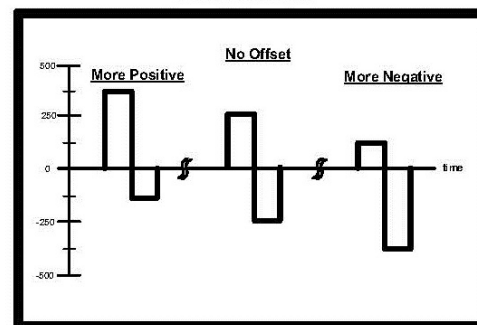

Figure #21

Recommended Processes and Equipment

RECOMMENDED PROCESSES

The Power Wave® Advanced Module is recommended for all process supported by the host power source including, but not limited to SMAW, GMAW, GMAW-P, GMAW-STT, GTAW.

PROCESS LIMITATIONS

The Advanced Module is rated for 300 amps at a 100% duty cycle and 350 amps at a 40% duty cycle rating. When connected to an S500 (CE) or R500 power source, the power source will acknowledge that the Advanced Module is connected and reduce the output capability to match that of the S350(CE) or R350 (300 amps, 32 volts at a 100% duty cycle and 350 amps, 34 volts at a 40% duty cycle). The Power Wave® Advanced Module is designed to protect itself from the excessive transient voltages associated with highly inductive weld circuits. These high inductance circuits may result in unsatisfactory performance, but will not damage the module.

Care should be taken to properly configure the input and

output welding cables to the Advanced Module per the connection diagrams. If a negative electrode polarity process such as Innershield is required, the switch will automatically reconfigure the output of the Advanced Module. If the input of the Advanced Module is reversed, the module will protect itself and block output capability.

Equipment Limitations

The Power Wave Advanced Module is intended for use with compatible medium range “S” – series Power Wave power sources such as the S350.

Legacy wire feeders such as the PF-10M are NOT RECOMMENDED for High Frequency TIG (GTAW) welding applications with the Advanced Module.

Case Front Descriptions

(see Figure #22)

- Negative:** Connects to Negative output of power source.
- Positive:** Connects to Positive output of power source.
- Voltage Sense Pigtail:** Provides voltage feedback to the power source from the module.

⚠ WARNING

Must be connected to provide accurate voltage feedback, even when sensing from the studs.

- Power source mounting bracket:** Provides a quick and reliable union between power source and module.
- Status led:** Provides ArcLink® status of Power Wave® Advanced Module.
Note: During normal power-up, the LED will flash green up to 60 seconds as the equipment performs self tests.
- Sense leade output:** Provides voltage feedback for remote electrode and work sense leads.

LED condition	Definition
Steady green.	System okay. The power source, wire feeder and module are communicating normally.
Blinking green.	Occurs during a reset and indicates the power source is identifying each component in the system. This is normal for the first 60 seconds after power-up, or if the system configuration is changed during operation.
Alternating green and red	Non-recoverable system fault. If the power source, wire feeder or modules status LED are flashing any combination of red and green, errors are present in the system. Read the error code before the machine is turned off.

Note: The 67 pin in 4 pin connector, located on power source case front is disconnected internally on the S350 CE.

- Work:** Connects to workpiece, regardless of process.
- GMAW electrode:** Connects to feeder for GMAW welding, regardless of process.
- GTAW/ SMAW electrode:** Connected internally to GMAW ELECTRODE, but also provides high frequency capability for TIG starting, provides solenoid controlled gas pass through.
- Power source mounting feet:** Provides a quick

and reliable union between the module and a cooler or cart

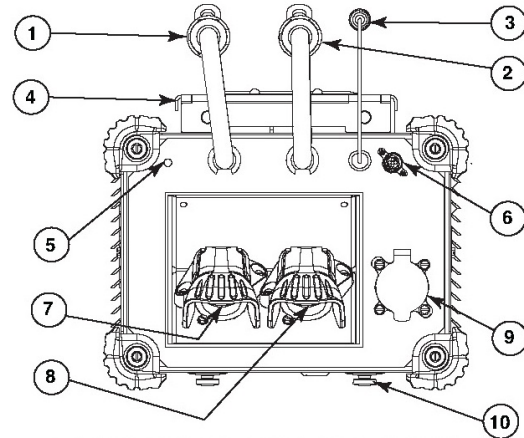

Figure #22

Case Back Descriptions

(see Figure #23)

- Differential I/O Pigtail:** Connects directly to the Differential I/O output receptacle on the rear of the power source.
- ArcLink® Pigtail:** Connects directly to the ArcLink® Out receptacle on the rear of the power source.
- Differential I/O (Sync Tandem) output:** Supports Synchronized Tandem MIG Welding with other compatible power sources.
- ArcLink® (out):** Provides an ArcLink® pass through connection for all compatible ArcLink® wire feeders.
- Gas input:** Provides a solenoid controlled gas feed to TIG ELECTRODE on Case Front.
- Water cooler pass through:** Provides a channel to conceal and protect the power and control leads for the optional integrally mounted CE Water Cooler.

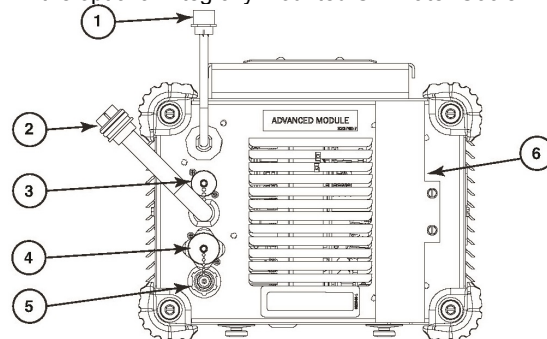

Figure #23

Maintenance

⚠ WARNING

For any maintenance or repair operations it is recommended to contact the nearest technical service center or Lincoln Electric. Maintenance or repairs performed by unauthorized service centers or personnel will null and void the manufacturer's warranty.

Routine Maintenance

Routine maintenance consists of periodically blowing out the machine, using a low-pressure air stream, to remove accumulated dust and dirt from the intake and outlet louvers, and the cooling channels in the machine. Also verify the Advanced Module fan is operational when the

power source fan is activated.

Calibration Specification

Due to the nature of its operation, calibration of the Advanced Module is not required. From a system perspective, the output calibration of the power source and wire feeder should be performed as directed in their respective instruction manuals.

When calibrating the power source voltage with an Advanced Module installed, the actual output voltage should be measured directly at the "Electrode" and "Work studs of the Advanced Module, not the output studs of the power source. This is necessary as the power source is configured to monitor voltage at the output studs of the Advanced Module, not the output studs of the power source. The Advanced Module has no effect on the output current calibration.

Customer Assistance Policy

The business of The Lincoln Electric Company is manufacturing and selling high quality welding equipment, consumables, and cutting equipment. Our challenge is to meet the needs of our customers and to exceed their expectations. On occasion, purchasers may ask Lincoln Electric for advice or information about their use of our products. We respond to our customers based on the best information in our possession at that time. Lincoln Electric is not in a position to warrant or guarantee such advice, and assumes no liability, with respect to such information or advice. We expressly disclaim any warranty of any kind, including any warranty of fitness for any customer's particular purpose, with respect to such information or advice. As a matter of practical consideration, we also cannot assume any responsibility for updating or correcting any such information or advice once it has been given, nor does the provision of information or advice create, expand or alter any warranty with respect to the sale of our products

Lincoln Electric is a responsive manufacturer, but the selection and use of specific products sold by Lincoln Electric is solely within the control of, and remains the sole responsibility of the customer. Many variables beyond the control of Lincoln Electric affect the results obtained in applying these types of fabrication methods and service requirements.

Subject to Change – This information is accurate to the best of our knowledge at the time of printing. Please refer to www.lincolnelectric.com for any updated information.

WEEE

07/06

English



Do not dispose of electrical equipment together with normal waste!

In observance of European Directive 2012/19/EC on Waste Electrical and Electronic Equipment (WEEE) and its implementation in accordance with national law, electrical equipment that has reached the end of its life must be collected separately and returned to an environmentally compatible recycling facility. As the owner of the equipment, you should get information on approved collection systems from our local representative.

By applying this European Directive you will protect the environment and human health!

Spare Parts

12/05

For Spare Parts references visit the Web page: <https://www.lincolnelectric.com/LEExtranet/EPC/>

Authorized Service Shops Location

09/16

- The purchaser must contact a Lincoln Authorized Service Facility (LASF) about any defect claimed under Lincoln's warranty period.
- Contact your local Lincoln Sales Representative for assistance in locating a LASF or go to www.lincolnelectric.com/en-gb/Support/Locator.

Electrical Schematic

WIRING DIAGRAM -

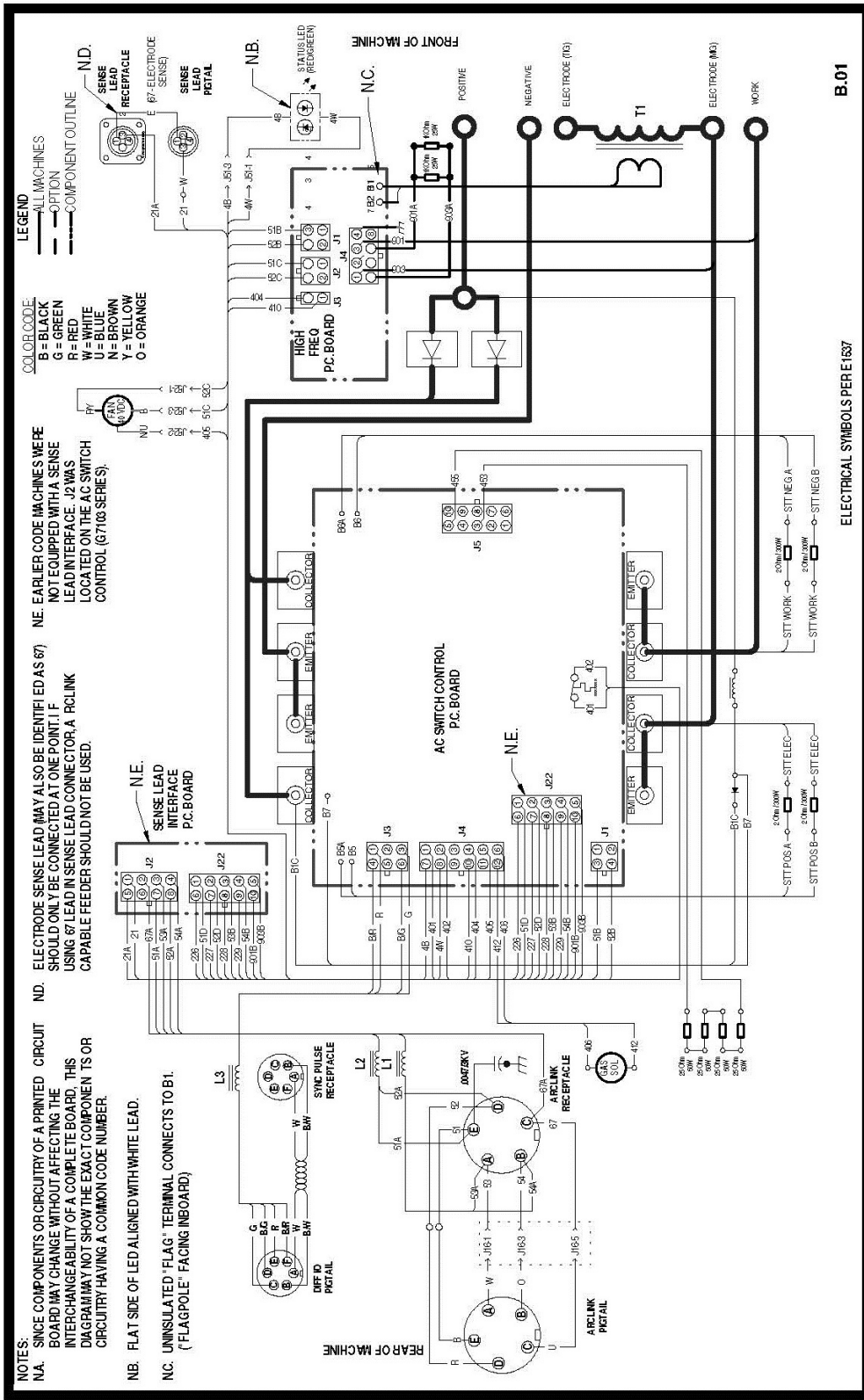

B.01
ELECTRICAL SYMBOLS PER E1837

M24668

NOTE: this diagram is for reference only. It may not be accurate for all machines covered by this manual. The specific diagram for a particular code is pasted inside the machine on one of the enclosure panels. If the diagram is illegible, write to the Service Department for a replacement. Give the equipment code number.

Suggested Accessories

Basic Package (STANDARD)	
Item number	Description
K2912-1	Power Wave [®] Advanced Module CE
K2823-2	Power Wave [®] S350 CE
K3328-X	Power Feed [®] 84
K1543-xx	ArcLink [®] Cable (5 pin) – connects wire feeder to power source.
K3086-1	Cool Arc 55
K2212-2	Python – water cooled push pull gun
Basic Package (ALUMINUM)	
K4912-1	Advanced Module Aluminum
K4188-1	Power Wave [®] S350 Aluminum
K4191-1	POWER FEED [®] -25M Aluminum
K4190-1	Cool Arc 55 Aluminum
K3355-2	Magnum Pro Aluminum Push Pull Gun (Air Cooled)
K3357-2	Magnum Pro Aluminum Push Pull Gun (Water Cooled)
Optional Wire Feeder	
K2536	POWER FEED [®] -25M
BASIC PACKAGE (CE)	
K2912-1	Power Wave [®] Advanced Module CE
K2823-2	Power Wave [®] S350 CE
K14072-1	LF-45
K1543-xx	ArcLink [®] Cable (5 pin) – connects wire Feeder to power source.
K14050-1	Cool Arc 50