

IM3075
11/2022
REV07

SPEEDTEC 320CP SPEEDTEC 320CP Push Pull

OPERATOR'S MANUAL



ENGLISH



Lincoln Electric Bester Sp. z o.o.
ul. Jana III Sobieskiego 19A, 58-260 Bielawa, Poland
www.lincolnelectric.eu

THANKS! For having chosen the QUALITY of the Lincoln Electric products.

- Please Examine Package and Equipment for Damage. Claims for material damaged in shipment must be notified immediately to the dealer.
- For future reference record in the table below your equipment identification information. Model Name, Code & Serial Number can be found on the machine rating plate.

Model Name:
Code & Serial number:
Date & Where Purchased:

INDEX

Technical Specifications.....	1
ECO design information	2
Electromagnetic Compatibility (EMC)	4
Safety.....	5
Installation and Operator Instructions	7
WEEE	Błąd! Nie zdefiniowano zakładki.
Spare Parts.....	24
REACH.....	24
Authorized Service Shops Location	24
Electrical Schematic	24
Accessories	25

Technical Specifications

NAME	INDEX
SPEEDTEC 320CP	K14168-1
SPEEDTEC 320CP PUSH PULL	K14168-2
PRIMARY SIDE	
Primary power supply	400 V +/-20%
Primary power supply frequency	50/60 Hz
Effective primary consumption	12 A
Maximum primary consumption	18,7 A
Fuse primary	16 A Gg
Maximum apparent power	13,1 kVA
Maximum active power	12,1 kW
Active power in standby (IDLE)	26 W
Efficiency at maximum current	0,86
Power factor at maximum current	0,91
Cos Phi	0,99
SECONDARY SIDE	
No load voltage (according standard)	74 V
Welding range MIG	10 V / 50 V
Welding range MMA	15 A / 320 A
Duty cycle at 100% (10 min cycle at 40°C)	220 A
Duty cycle at 60% (6 min cycle at 40°C)	280 A MIG / 270 A MMA
Duty cycle at maximum current at 40°C	320 A (40%)
WIRE FEEDER	
Rollers plate	4 rollers
Wire feeding speed	0,5 – 25,0 m / mn
Wire diameter usable	0.6 to 1,2 mm
Weight, type, size of wire spool	300 mm / 20Kg maximum
Maximum pressure of gas	5 bar
MISCELLEANOUS	
Dimensions (Lxwxh)	743 x 335,4 x 533,75 mm
Weight	37 kg
Weight with spool 20kg	58,4 kg
Operating temperature	- 10°C/+40°C
Storage temperature	- 20°C/+55°C
Torch connection	"European type"
Protection index	IP 23
Insulation class	H
Standard	60974-1, 60974-5, 60974-10

ECO design information

The equipment has been designed in order to be compliant with the Directive 2009/125/EC and the Regulation 2019/1784/EU.

Efficiency and idle power consumption:

Index	Name	Efficiency when max power consumption / Idle power consumption	Equivalent model
K14168-1	SPEEDTEC 320CP	85% / 28W	No equivalent model
K14168-2	SPEEDTEC 320CP PUSH PULL	85% / 28W	No equivalent model

Idle state occurs under the condition specified in below table

IDLE STATE	
Condition	Presence
MIG mode	X
TIG mode	
STICK mode	
After 30 minutes of non-working	
Fan off	X

The value of efficiency and consumption in idle state have been measured by method and conditions defined in the product standard EN 60974-1:20XX.

Manufacturer's name, product name, code number, product number, serial number and date of production can be read from rating plate.

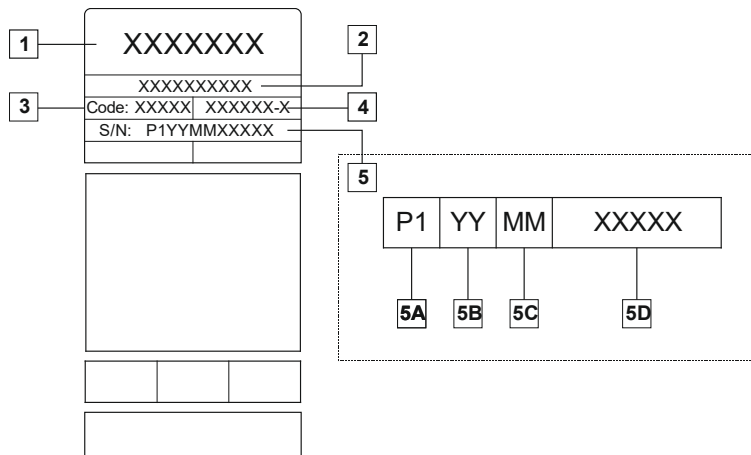

Where:

- 1- Manufacturer name and address
- 2- Product name
- 3- Code number
- 4- Product number
- 5- Serial number
 - 5A- country of production
 - 5B- year of production
 - 5C- month of production
 - 5D- progressive number different for each machine

Typical gas usage for **MIG/MAG** equipment:

Material type	Wire diameter [mm]	DC electrode positive		Wire Feeding [m/min]	Shielding Gas	Gas flow [l/min]
		Current [A]	Voltage [V]			
Carbon, low alloy steel	0,9 ÷ 1,1	95 ÷ 200	18 ÷ 22	3,5 – 6,5	Ar 75%, CO ₂ 25%	12
Aluminium	0,8 ÷ 1,6	90 ÷ 240	18 ÷ 26	5,5 – 9,5	Argon	14 ÷ 19
Austenitic stainless steel	0,8 ÷ 1,6	85 ÷ 300	21 ÷ 28	3 - 7	Ar 98%, O ₂ 2% / He 90%, Ar 7,5% CO ₂ 2,5%	14 ÷ 16
Copper alloy	0,9 ÷ 1,6	175 ÷ 385	23 ÷ 26	6 - 11	Argon	12 ÷ 16
Magnesium	1,6 ÷ 2,4	70 ÷ 335	16 ÷ 26	4 - 15	Argon	24 ÷ 28

Tig Process:

In TIG welding process, gas usage depends on cross-sectional area of the nozzle. For commonly used torches:

Helium: 14-24 l/min.

Argon: 7-16 l/min.

Notice: Excessive flow rates causes turbulence in the gas stream which may aspirate atmospheric contamination into the welding pool.

Notice: A cross wind or draft moving can disrupt the shielding gas coverage, in the interest of saving of protective gas use screen to block air flow.



End of life

At end of life of product, it has to be disposal for recycling in accordance with Directive 2012/19/EU (WEEE), information about the dismantling of product and Critical Raw Material (CRM) present in the product, can be found at <https://www.lincolnelectric.com/en-gb/support/Pages/operator-manuals-eu.aspx>.

Electromagnetic Compatibility (EMC)

01/11

This machine has been designed in accordance with all relevant directives and standards. However, it may still generate electromagnetic disturbances that can affect other systems like telecommunications (telephone, radio, and television) or other safety systems. These disturbances can cause safety problems in the affected systems. Read and understand this section to eliminate or reduce the amount of electromagnetic disturbance generated by this machine.



This machine has been designed to operate in an industrial area. To operate in a domestic area it is necessary to observe particular precautions to eliminate possible electromagnetic disturbances. The operator must install and operate this equipment as described in this manual. If any electromagnetic disturbances are detected the operator must put in place corrective actions to eliminate these disturbances with, if necessary, assistance from Lincoln Electric.

Provided that the public low voltage system impedance at the point of common coupling is lower than 97mΩ, this equipment is compliant with IEC 61000-3-11 and 61000-3-12 and can be connected to public low voltage systems. It is the responsibility of the installer or user of the equipment to ensure by consultation with the distribution network operator if necessary, that the system impedance complies with the impedance restrictions.

Before installing the machine, the operator must check the work area for any devices that may malfunction because of electromagnetic disturbances. Consider the following.

- Input and output cables, control cables, and telephone cables that are in or adjacent to the work area and the machine.
- Radio and/or television transmitters and receivers. Computers or computer controlled equipment.
- Safety and control equipment for industrial processes. Equipment for calibration and measurement.
- Personal medical devices like pacemakers and hearing aids.
- Check the electromagnetic immunity for equipment operating in or near the work area. The operator must be sure that all equipment in the area is compatible. This may require additional protection measures.
- The dimensions of the work area to consider will depend on the construction of the area and other activities that are taking place.

Consider the following guidelines to reduce electromagnetic emissions from the machine.

- Connect the machine to the input supply according to this manual. If disturbances occur it may be necessary to take additional precautions such as filtering the input supply.
- The output cables should be kept as short as possible and should be positioned together. If possible connect the work piece to ground in order to reduce the electromagnetic emissions. The operator must check that connecting the work piece to ground does not cause problems or unsafe operating conditions for personnel and equipment.
- Shielding of cables in the work area can reduce electromagnetic emissions. This may be necessary for special applications.



EMC classification of this product is class A in accordance with electromagnetic compatibility standard EN 60974-10 and therefore the product is designed to be used in an industrial environment only.





The Class A equipment is not intended for use in residential locations where the electrical power is provided by the public low-voltage supply system. There can be potential difficulties in ensuring electromagnetic compatibility in those locations, due to conducted as well as radio-frequency disturbances.











WARNING

This equipment must be used by qualified personnel. Be sure that all installation, operation, maintenance and repair procedures are performed only by qualified person. Read and understand this manual before operating this equipment. Failure to follow the instructions in this manual could cause serious personal injury, loss of life, or damage to this equipment. Read and understand the following explanations of the warning symbols. Lincoln Electric is not responsible for damages caused by improper installation, improper care or abnormal operation.

	<p>WARNING: This symbol indicates that instructions must be followed to avoid serious personal injury, loss of life, or damage to this equipment. Protect yourself and others from possible serious injury or death.</p>
	<p>READ AND UNDERSTAND INSTRUCTIONS: Read and understand this manual before operating this equipment. Arc welding can be hazardous. Failure to follow the instructions in this manual could cause serious personal injury, loss of life, or damage to this equipment.</p>
	<p>ELECTRIC SHOCK CAN KILL: Welding equipment generates high voltages. Do not touch the electrode, work clamp, or connected work pieces when this equipment is on. Insulate yourself from the electrode, work clamp, and connected work pieces.</p>
	<p>ELECTRICALLY POWERED EQUIPMENT: Turn off input power using the disconnect switch at the fuse box before working on this equipment. Ground this equipment in accordance with local electrical regulations.</p>
	<p>ELECTRICALLY POWERED EQUIPMENT: Regularly inspect the input, electrode, and work clamp cables. If any insulation damage exists replace the cable immediately. Do not place the electrode holder directly on the welding table or any other surface in contact with the work clamp to avoid the risk of accidental arc ignition.</p>
	<p>ELECTRIC AND MAGNETIC FIELDS MAY BE DANGEROUS: Electric current flowing through any conductor creates electric and magnetic fields (EMF). EMF fields may interfere with some pacemakers, and welders having a pacemaker shall consult their physician before operating this equipment.</p>
	<p>CE COMPLIANCE: This equipment complies with the European Community Directives.</p>
 <p><small>Optical radiation emission: Category 2 (EN 12195)</small></p>	<p>ARTIFICIAL OPTICAL RADIATION: According with the requirements in 2006/25/EC Directive and EN 12198 Standard, the equipment is a category 2. It makes mandatory the adoption of Personal Protective Equipment (PPE) having filter with a protection degree up to a maximum of 15, as required by EN169 Standard.</p>
	<p>FUMES AND GASES CAN BE DANGEROUS: Welding may produce fumes and gases hazardous to health. Avoid breathing these fumes and gases. To avoid these dangers the operator must use enough ventilation or exhaust to keep fumes and gases away from the breathing zone.</p>
	<p>ARC RAYS CAN BURN: Use a shield with the proper filter and cover plates to protect your eyes from sparks and the rays of the arc when welding or observing. Use suitable clothing made from durable flame-resistant material to protect you skin and that of your helpers. Protect other nearby personnel with suitable, non-flammable screening and warn them not to watch the arc nor expose themselves to the arc.</p>

	<p>WELDING SPARKS CAN CAUSE FIRE OR EXPLOSION: Remove fire hazards from the welding area and have a fire extinguisher readily available. Welding sparks and hot materials from the welding process can easily go through small cracks and openings to adjacent areas. Do not weld on any tanks, drums, containers, or material until the proper steps have been taken to insure that no flammable or toxic vapors will be present. Never operate this equipment when flammable gases, vapors or liquid combustibles are present.</p>
	<p>WELDED MATERIALS CAN BURN: Welding generates a large amount of heat. Hot surfaces and materials in work area can cause serious burns. Use gloves and pliers when touching or moving materials in the work area.</p>
	<p>CYLINDER MAY EXPLODE IF DAMAGED: Use only compressed gas cylinders containing the correct shielding gas for the process used and properly operating regulators designed for the gas and pressure used. Always keep cylinders in an upright position securely chained to a fixed support. Do not move or transport gas cylinders with the protection cap removed. Do not allow the electrode, electrode holder, work clamp or any other electrically live part to touch a gas cylinder. Gas cylinders must be located away from areas where they may be subjected to physical damage or the welding process including sparks and heat sources.</p>
<p>HF</p>	<p>CAUTION: The high frequency used for contact-free ignition with TIG (GTAW) welding, can interfere with the operation of insufficiently shielded computer equipment, EDP centers and industrial robots, even causing complete system breakdown. TIG (GTAW) welding may interfere with electronic telephone networks and with radio and TV reception.</p>
	<p>EQUIPMENT WEIGHT OVER 30kg: Move this equipment with care and with the help of another person. Lifting may be dangerous for your physical health.</p>
	<p>NOISE APPEARES DURING WELDING CAN BE HARMFUL: Welding arc can cause noise with high level of 85dB for 8-hour week day. Welders operating welding machines are obligated to wear the proper ear protectors. Employers are obligated to carry examinations and measurements of health harmful factors.</p>
	<p>SAFETY MARK: This equipment is suitable for supplying power for welding operations carried out in an environment with increased hazard of electric shock.</p>

The manufacturer reserves the right to make changes and/or improvements in design without upgrade at the same time the operator's manual.

Installation and Operator Instructions

General description

SPEEDTEC 320CP / SPEEDTEC320CP PP is a manual welding set that enables the following:



- MIG-MAG welding with short arc, speed short arc, spray-arc, normal pulsed mode using currents from 15A to 320A.
- SPEEDTEC 320CP / PP work with the water cooler COOLARC 46.
- Feeding different types of wire
 - steel, stainless steel, aluminum and special wires
 - solid and cored wires
 - diameters from 0.6-0.8-1.0-1.2 mm

Welding set components

The welding set consists of 4 main components:

1. power source including its primary cable (5m) without plug
2. gas hose kit assembly (2m)
3. work lead (3m)
4. rolls for solid wire V1.0/V1.2
5. USB key containing Instruction Manual

Recommended equipment, which can be bought by user, was mentioned in the chapter "Accessories".

Read this entire section before installation or operation of the machine.

⚠ WARNING

The plastic handles are not intended for slinging the set.

Stability of the equipment is guaranteed only for an incline of maximum 15°.

Location and Environment

This machine will operate in harsh environments. However, it is important that simple preventative measures are followed to assure long life and reliable operation.

- Do not use this machine for pipe thawing.
- This machine must be located where there is free circulation of clean air without restrictions for air movement to and from the air vents. Do not cover the machine with paper, cloth or rags when switched on.
- Dirt and dust that can be drawn into the machine should be kept to a minimum.
- This machine has a protection rating of IP23. Keep it dry when possible and do not place it on wet ground or in puddles.
- Locate the machine away from radio controlled machinery. Normal operation may adversely affect the operation of nearby radio controlled machinery, which may result in injury or equipment damage. Read the section on electromagnetic compatibility in this manual.
- Do not operate in areas with an ambient temperature greater than 40°C.

Duty cycle and overheating

- Duty cycle is the percentage of 10 minutes at 40°C ambient temperature that the unit can weld at its rated output without overheating.
- If the unit overheats, the output stops and the over temperature light comes On. To correct the situation, wait fifteen minutes for unit to cool.
- Reduce amperage, voltage or duty cycle before starting to weld again.

Starting up

The power source is composed with:



1. Front panel display
2. European plug for torch
3. Additional plug for 2 potentiometers torch
4. Plug for ground cable and polarity inversion
5. Protection door for wire feeder section
6. Spool axle, shaft, axle nut
7. Gas purge button
8. Cold wire feeding button
9. Wire driver

Input Supply Connection

WARNING

Only a qualified electrician can connect the welding machine to the supply network. Installation of the outlet plug to power lead and connecting the welding machine had to be made in accordance with the appropriate National Electrical Code and local regulations.

Check the input voltage, phase, and frequency supplied to this machine before turning it on. Verify the connection of grounding wires from the machine to the input source. **SPEEDTEC 320CP / PP** can only be connected to a mating grounded receptacle. Input voltage is 3x400V 50/60Hz. For more information about input supply refer to the technical specification section of this manual and to the rating plate of the machine.

Make sure that the amount of mains power available from the input supply is adequate for normal operation of the machine. The type of protection and cable sizes are indicated in the technical specification section of this manual.

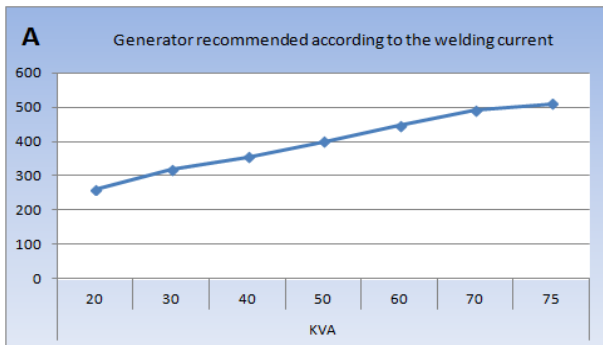

WARNING

The welding machine can be supplied from a power generator of output power at least 30% larger than input power of the welding machine. See "Technical Specifications" chapter.

WARNING

When powering welder from a generator be sure to turn off welding machine first, before generator is shut down, in order to prevent damage to welding machine!

To set up the wire:

- Turn the power source off.
- Open the door of the wire-feeder unit [5] and ensure that it can not fall.
- Unscrew the spool axle nut. [6].
- Insert the spool of wire on the axis. Make sure that the locating pin of the shaft [6] is properly located into the reel locator.
- Screw the spool nut [6] back on the shaft, turning it in the direction shown by the arrow.
- Lower the lever of wire driver [9] in order to release the rollers.
- Take the end of the wire of the spool and cut the distorted end piece.
- Straighten the first 15 centimeters of wire.
- Insert the wire via the inlet wire-guide of the plate.
- Lower the rollers [9] and raise the lever in order to immobilize it.
- Adjust the pressure of the rollers on the wire to the correct tension.

Wire feed

The wire feeding button (8) feeds the wire into the torch. The wire feeds over 1s at minimum speed and the speed increases gradually until the set wire speed is reached, but is limited to 12 m/min. The settings may be change at any time; the power source displays the speed.

To feed the wire through the torch. Maintain the wire feeding button (8).

Wire speed can be adjusted with the button on front panel.

To full the gas line or adjust the gas flow. Push the gas bleed button (7).

Wire driver wear part

The wearing parts of the wire driver, whose role is to guide and advance the welding wire, must be adapted to the type and diameter of the welding wire used. On the other hand, their wear may affect the welding results. Is necessary to replace them.

Connection of the torch

THE MIG WELDING TORCH IS CONNECTED TO THE FRONT OF THE POWER SOURCE, AFTER ENSURING IT HAS BEEN PROPERLY OUTFITTED WITH THE WEAR PARTS CORRESPONDING TO THE WIRE USED FOR WELDING.

For this purpose, please refer to the torch instructions.

Gas inlet connection

The gas inlet is positioned at the rear of the power source. Simply connect it to the pressure-regulator outlet of the gas cylinder.

- Place the gas cylinder on the trolley at the rear of the power source and fasten the bottle using the strap.
- Open the cylinder valve slightly to allow existing impurities to escape and then reclose it.
- Mount the pressure regulator/flowmeter.
- Open the gas cylinder.

During welding, the gas flow rate should be between 10 and 20l/min.

WARNING

Be sure that the gas cylinder is properly secured on the trolley by attaching the safety strap.

Switch on

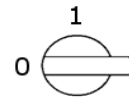

The main switch is located at the rear of the power source. **Flip this switch to turn the machine on.**

NOTE

This switch must never be flipped during welding.

At each start-up, the power source displays the software version and recognized power.

Instructions for use

Front panel functions



- Left display: Voltage, Right display: Current/ wire speed /wire thickness 1
- Display for selection of welding mode 2
- Selector button for welding mode 3
- Selector switch for welding process 4
- Measurement indicator of displayed values (pre-welding, welding and post-welding data) 5
- Led indicator for program mode 6
- Encoder voltage setup and navigation 7
- Encoder for current, wire speed, metal sheet thickness setup and navigation 8
- Display mode indicator current, wire speed, metal sheet thickness 9
- Selector button for pre-display and program management 10
- Selector switch for type of gas, wire diameter and type of welding wire 11

Calibrate the power source



Step 1: Turn the wire diameter switch to  position

and press the  to access the **CO**nFIG Setup screen.

Step 2: Select the **CaL** parameter with the left-hand encoder and select **On** with the right-hand encoder.

Step 3: Press the  on the front panel. The display unit indicates **triGER**.

Step 4: Remove the torch nozzle.

Step 5: Cut the wire.

Step 6: Place the piece in contact with the contact tube.

Step 7: Press the trigger.

Step 8: The display will indicate the value of L (cable inductance).

Step 9: Display the value of R using the right-hand encoder (cable resistance).



Step 10: Exit Setup.

WARNING

When starting up for the first time, the calibration is an unavoidable step to achieve quality welding. If polarity is reversed, this step must be repeated.

Display and use

Synergic mode

The Current, Voltage and Thickness values listed for each wire feed speed setting are provided for information purposes only. They correspond to measurements under given operating conditions, such as position, length of the end section (flat position welding, butt welding).

The units current/voltage displayed correspond to the average measured values, and they may differ from the theoretical values.

Measurement indicator of displayed values:

OFF: pre-welding display of instructions.

ON: Display of measurements (average values).

Flashing: Measurements during welding.

Selection of wire, diameter, gas, welding process

Select the type of wire, the wire diameter, the used welding gas and welding process by turning the appropriate switch.

Selection of the material will determine the available values for diameter, gas and processes.

If synergy doesn't exist, power source displays nOt SYn,GAS SYn,DdIA SYn,or Pro SYn.

Selection of welding mode, arc length and pre-welding display

Select welding mode 2S, 4S, spot, synergic and manual

by pressing . Arc length can be adjusted with left encoder (7) and pre-welding display adjustment is performed with right encoder (8). The selection of pre-

welding preset is performed with press button .

Manual mode

This is the disengaged mode of the welding machine. Adjustable parameters for it are wire speed, arc voltage and fine setting.

In this mode, only the wire speed value is displayed.

Have to select wire diameter, gas and welding process before starting welding.



SETUP mode

Accessing the SETUP:

The SETUP screen can only be accessed when no welding is in progress, by setting the Wire Diameter selector on the front panel to position 1.

It consist in two pull-down menu:

'CYCLE' → Setting for the cycle phases. Refer to table for detail.

'COnFIG' → Power source configuration.

Configuring the SETUP:

In SETUP position, select CYCLE or COnFIG by pressing



Turn the **left-hand** encoder to scroll through the available parameters.

Turn the **right-hand** encoder to set their value.

No welding start. All the changes are saved on exiting the SETUP menu.

List of accessible parameters in COnFIG menu				
Left display	Right display	Step	Default	Description
GrE	On -; OFF – Aut		Aut	Configuration of the Water Cooling Unit. 3 possibles states : - On : Forced on, watercooler is always activated; - OFF : Forced off, watercooler is always deactivated, - Aut : Automatic mode, Watercooler works when according need.
ScU	nc – no - OFF		OFF	Security of water cooling. 3 possible states : - nc : Normally closed; - no : Normally open, - OFF : Deactivate.
Unit	US – CE		CE	Unit displayed for wire speed and thickness: - US : inch unit; - CE : meter unit.
CPT	OFF– 0,01 – 1,00	0,01 s	0,30	Trigger holding time in order to call program (Only in 2S welding mode). Can be used only for welding program from 50 to 99.
PGM	no – yES		No	Activate / deactivate program management mode
PGA	OFF – ; 000 – 020 %	1%	OFF	Use to setup available adjustment range of the following parameters: wire speed, arc voltage, arc dynamics, pulse fine-setting. Use only when program management is activated and programs are locked.
Adj	Loc – rC		Loc	Select adjustment Wire speed and arc voltage : - Loc : Local on the power source; - rC : remote Control or torch potentiometer.
CAL	OFF – on		OFF	Calibration of torch & ground harness.
L	0 – 50	1 uH	14	Cable choke setting / display.
r	0 – 50	1 Ω	8	Cable resistor setting / display.
SoF	no – yES		No	Software update mode.
FAC	no – yES		No	Factory settings reset. Pressing YeS will cause a reset of the parameters to factory defaults when exit  .
List of accessible parameters in CYCLE menu				
Left display	Right display	Step	Default	Description.
tPt	00.5 – 10.0	0,1 s	0,5	Spot time. In Spot mode and in Manual mode, the Hot Start, Downslope and sequencer settings cannot be changed.
PrG	00.0 – 10.0	0,1 s	0,5	Pre-gas time.
tHS	OFF – 00.1 – 10.0	0,1 s	0,1	Hot start time.
IHS	-- 70 – 70	1 %	30	Hot start current (wire speed). X% ± the welding current.
UHS	-- 70 – 70	1 %	0	Hot start voltage X% ± the arc voltage.
dYn	--10 + 10 --20 + 20	1 %	0	Fine setting in short arc.
rFP	--10 + 10 --20 + 20	1 %	0	Fine setting in pulse.
dyA	00 – 100	1	50	Arc striking dynamics at electrode.
tSE	OFF – 0.01 – 2.50	0,01 s	OFF	Sequencer time (Sequencer, only in synergic mode).
ISE	--90 + 90	1 %	30	Sequencer current level. X% ± the welding current.
dSt	OFF – 00.1 – 05.0	0,1 s	OFF	Down-slope time.
DdSI	-- 70 – 00.0	1 %	-- 30	Down-slope current (wire speed). X% ± the welding current.
dSU	-- 70 – 70	1 %	0	Down-slope voltage. X% ± the arc voltage.
Pr	0.00 – 0.20	0,01 s	0,05	Anti-stick time.
PrS	Nno – yES		no	Pr-Spray activation.
PoG	00.0 – 10.0	0,05 s	0,05	Post-gas time.

Program management

SPEEDTEC 320CP / PP allows creating, storing and modifying up to 99 welding programs directly on front panel from program 01 to program 99. This function is activated by moving parameter PGM from no to YES in CONFIG menu.

P00 is the working program in any state. (Program management mode activated or deactivated). When power source is working on this program, the Led indicator "JOB" is switched off. All commutators are accessible in this mode, so it will be used to set programs.

P01 to P99 are program saved, only if program management mode is activated. When power source is working on these programs, the led indicator "JOB" is switched on. In this mode, commutators welding process, wire diameter, gas and metal are not available. When a program selected has been modified, the indicator "JOB" blinks.

Create and save a program:

These paragraph explains how to create, modify and save a welding program. Hereunder is explained the common menu used.

1. Activate program management mode:  → PGM
→ put YES → exit 
2. Set your program with the 4 commutators (4) and (11)
then long push 
3. Screen displays message as following:



Program call with trigger

This function allows to chain from 2 to 10 programs. This function is available in 4S welding mode only and program management mode has to be activated.

Program chaining:

The function program call works with programs from P50 to P99 by ten.

- P50→P59 ; P60→P69 ; P70→P79 ; P80→P89 ; P90→P99

Select first program with which you want to begin your chain. Then during welding, each time you will push trigger, program will change.

To chain less than ten programs, in the program following end of loop desired put a different parameter (As synergy or welding cycle).

It is possible to setup time of trigger push to detect change

of program chain:  → CPT → put value from 1 to

100 → exit 

Example: Create a program list from P50 to P55 (6 programs).

In program P56, put different welding cycle or synergy than P55 in order to finish chain

Select program P50 (First program for start of welding

Start welding

Each time trigger will be pushed, power source will change program until P55. When chain is finished, power source will restart to P50.

Output Connections

A quick disconnect system using Twist-Mate™ cable plugs is used for the welding cable connections. Refer to the following sections for more information on connecting the machine for operation of stick welding (MMA) or TIG welding.

(+) Positive Quick Disconnect: Positive output connector for the welding circuit.

(-) Negative Quick Disconnect: Negative output connector for the welding circuit.

Stick Welding (MMA)

First determine the proper electrode polarity for the electrode to be used. Consult the electrode data for this information. Then connect the output cables to the output terminals of the machine for the selected polarity.

Shown here is the connection method for DC(+) welding. Connect the electrode cable to the (+) terminal and the work clamp to the (-) terminal. Insert the connector with the key lining up with the keyway and rotate approximately 1/4 turn clockwise. Do not over tighten. For DC(-) welding, switch the cable connections at the machine so that the electrode cable is connected to (-) and the work clamp is connected to (+).

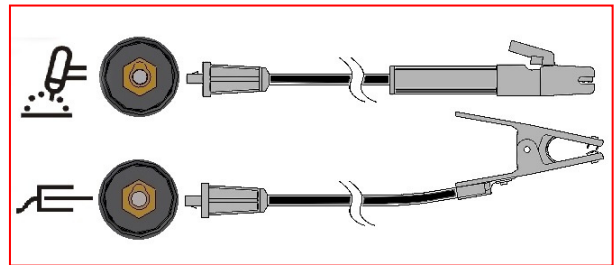

Remote Control Connection



Refer to the accessories section for a list of remote controls. If a remote control is used, it will be connected to the remote connector on the front of the machine. The machine will automatically detect the remote control, turn on the REMOTE LED, and switch to remote control mode. More information on this mode of operation will be given in the next section.

Other Controls and Features

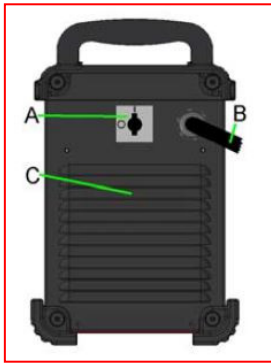

- A:** Power Switch: It turns ON/OFF the input power to the machine.
- B:** Input cable: Connect it to the mains.
- C:** Fan. This machine has a F.A.N. (Fan As Needed)

Circuitry inside: the fan is automatically turned ON or OFF. This feature reduces the amount of dirt which can be drawn inside the machine and reduces power consumption. When the machine is turned ON the fan will turn ON. The fan will continue to run whenever the machine is welding. If the machine doesn't weld for more than five minutes, the fan will turn OFF.

D: Water Cooler Connection **SPEEDTEC 320CP / PP** work with the water cooler **COOLARC 46** (see "Accessories" chapter).

WARNING

Read and understand the cooler manual before connecting it to the power source. Before connecting cooler, refer to the manual of wire feeder.



The **COOLARC 46** is supplied by welding power source using 9-PIN socket.

Input voltages is 400V, 50/60Hz. Make sure that the supply voltage of the unit matches the cooler's rated voltage.

To connect the water cooler COOLARC 46 to the power source:

- Turn off the power source and disconnect input plug.
- Remove the cap from the Water Cooler Supply Socket.
- Insert 9-pin plug of the water cooler power lead into the Water Cooler Power Supply Socket.

WARNING

Do not switch on the welding power source with the cooler applied if the reservoir was not filled and the torch's/gun's hoses are disconnected from the cooling unit. The non-observance of this warning may cause internal damages at the cooler unit.

Presentation of welding processes

For carbon and stainless steels, **SPEEDTEC 320CP / PP** uses 2 types of short arc:

- "soft" or "smooth" short arc
- The "dynamic" short arc or « SSA ».

PULSED MIG MAY BE USED ON ALL TYPES OF METAL (STEEL, STAINLESS STEEL AND ALUMINIUM) WITH SOLID WIRES AND SOME CORED WIRES. IT IS PARTICULARLY SUITABLE FOR STAINLESS STEEL AND ALUMINIUM, FOR WHICH IT IS THE IDEAL PROCESS, ELIMINATING SPATTER AND ACHIEVING EXCELLENT WIRE FUSION.

Characteristics of the power source arc

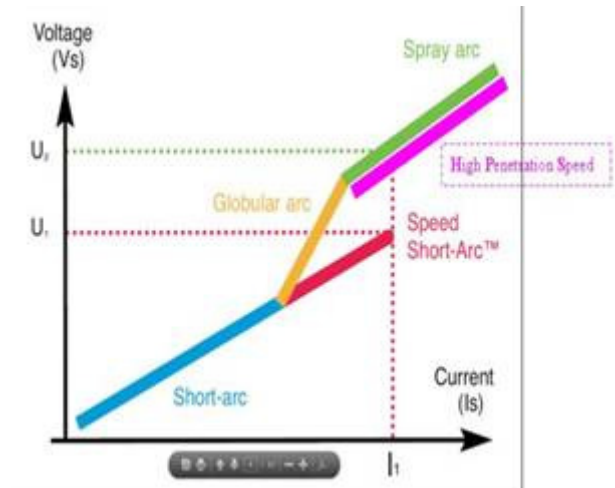

"Soft" or "Smooth" short arc (SA)

The "soft" short arc achieves **great reduction in spatter** when welding carbon steels, resulting in a very significant reduction in finishing costs.

It improves the appearance of the weld bead thanks to improved wetting of the molten pool.

The "soft" short arc is suitable for welding in all positions. An increase in wire feed speed enables entering spray arc mode without preventing transition into globular mode.

Waveform of short arc welding process



NOTE

The "soft" short arc is slightly more energetic than the "speed" short arc. Consequently the "speed" short arc may be preferable to the "soft" short arc for welding very thin sheets (≤ 1 mm) or for welding penetration passes.



“Dynamic” short arc or “Speed Short Arc” (SSA)

The Speed Short Arc or SSA allows greater versatility in welding carbon and stainless steels and absorbs fluctuations in the welder’s hand movements, for example when welding in a difficult position. It also helps compensate for differences in the preparation of the work pieces.

By increasing the wire feed speed, the SA mode enters seamlessly into SSA mode, while preventing the globular mode.

Thanks to its quick arc control and using appropriate programming, **SPEEDTEC 320CP / PP** can artificially extend the Short Arc range to higher currents, in the range of the **speed short arc**.

Waveform of speed short arc welding process



By eliminating the "globular" arc mode, which is characterized by heavy and sticky spatter and higher energy than the short arc, the speed short arc enables to:

- Reduce the amount of distortions at high welding currents in the typical "globular" welding range
- Reduce the amount of spatter compared to the globular mode
- Achieve good weld appearance
- Reduce smoke emissions compared with the usual modes (up to 25% less)
- Achieve good rounded penetration
- Enable welding in all positions



NOTE

The CO₂ programmes automatically and exclusively use the “soft” short arc and do not enable access to the speed short arc. The “dynamic” short arc is not suitable for CO₂, welding due to arc instability.



NORMAL Pulsed MIG

Metal transfer in the arc takes place by detachment of droplets caused by current pulses. The microprocessor calculates all the Pulsed MIG parameters for each wire speed, to ensure superior welding and striking results.

- The advantages of pulsed MIG are :
- Reduced distortions at high welding currents in the customary "globular" welding and spray arc ranges
- Enables all welding positions
- Excellent fusion of stainless steel and aluminum wires
- Almost complete elimination of spatter and hence of finishing work
- good bead appearance
- Reduced smoke emissions compared with customary methods and even-speed short-arc (up to 50% less);

Pulsed **SPEEDTEC 320CP / PP** programs for stainless steel eliminate the small spatter that may occur on thin sheets at very low wire feed speeds. These "balls" are caused by slight spraying of the metal at the time of droplet detachment. The extent of this phenomenon depends on the type and origin of the wires.

These programmes for stainless steel have undergone improvements for operation at low currents and increasing the flexibility of use for thin sheet welding using Pulsed MIG method.

Excellent results for welding thin stainless steel sheets (1 mm) are obtained using the pulsed MIG method with Ø 1 mm wire in M12 or M11 shield (average 30A is acceptable).

The appearance of joints processed using, **SPEEDTEC 320CP / PP** is of a quality comparable with that achieved by TIG welding.

Advanced welding cycle

Step cycle 2S

Pressing the trigger activates wire feed and pre-gas and turns on the welding current. Releasing the trigger causes the welding to stop.

The Hot Start cycle is validated by the **tHS≠OFF**



parameter in the general Cycle submenu of the . It enables starting the welding with a current peak that facilitates striking.

The down-slope enables weld bead finish with a decreasing level of welding.

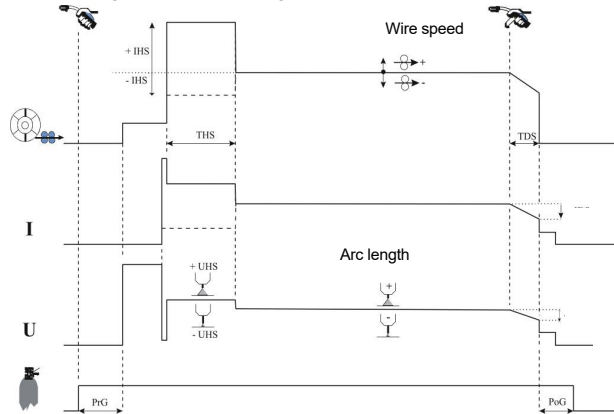

Step cycle 4S

Pulling the trigger the first time activates the pre-gas, followed by Hot Start. Releasing the trigger starts the welding.

If HOT START is not active, welding will start immediately after pre-gas. In such a case, releasing the trigger (2nd step) will have no effect, and the welding cycle will continue.

Pressing the trigger in the welding phase (3rd step) enables control of the duration of the down-slope and anti-crater functions, according to the pre-programmed time delay.

If there is no down-slope, releasing the trigger will immediately switch into post-gas (as programmed in the Setup).

In 4-Step mode (4S), releasing the trigger stops the anti-crater function if slope-down is ENABLED.

If slope-down is DISABLED, releasing the trigger will stop the POST-GAS.

The Hot Start and slope-down functions are not available in manual mode.

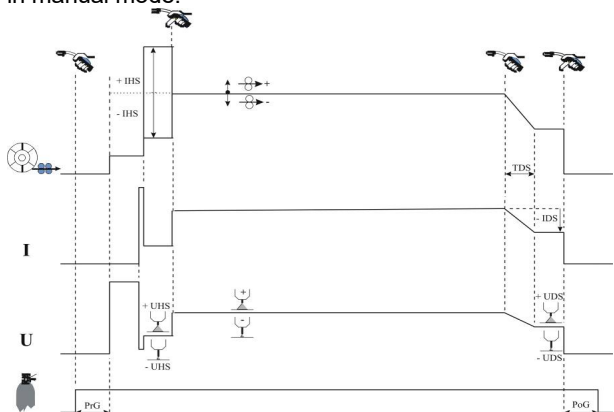

Spot cycle (...)

Pressing the trigger activates wire feed and pre-gas and turns on the welding current. Releasing the trigger causes the welding to stop.

Adjustment of the Hot Start, down-slope and sequencer settings is disabled. At the end of the spot time-delay, welding stops.

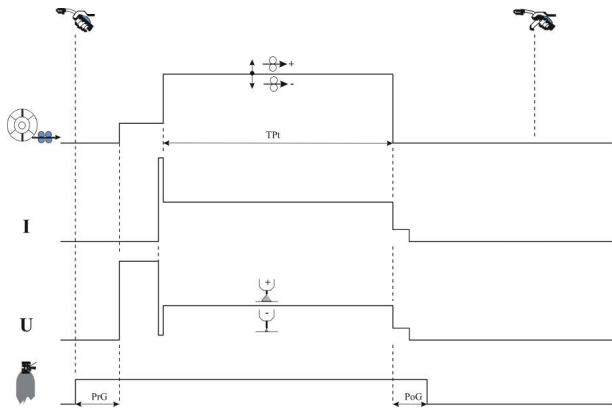

Sequencer cycle

The sequencer is validated by the parameter "tSE≠0ff" in



the specific cycle submenu of

To access it :

The "tSE" parameter is displayed in the "CYCLE" menu

Set this parameter to a value between 0 and 9.9 s.

tSE : DURATION OF THE 2 STEPS if ≠ Off.

ise : 2nd level current as % of the 1st level.

AVAILABLE ONLY IN SYNERGIC MODE, 2T CYCLE, OR 4T CYCLE

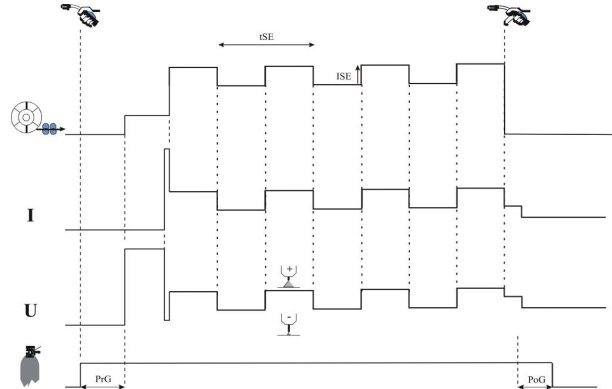

Fine setting

(parameter adjustable in the "rFP cycle setup menu)

In pulsed welding, the fine-setting function enables optimizing the place of droplet detachment according to the variation in the compositions of utilized wires and welding gases.

When fine spatter that may adhere to the work piece is observed in the arc, the fine-tune setting must be changed toward negative values.

If large drops are transferred by the arc, the fine-tune setting must be changed towards positive values.

In Smooth mode (short arc), lowering the fine-tune setting enables achieving a more dynamic transfer mode and the possibility of welding while reducing the energy carried to the weld pool by shortening the arc length.

A higher fine-tune setting causes an increase in arc length. A more dynamic arc facilitates welding in all positions, but has the disadvantage of causing more spatters.

PR-spray or wire sharpening

The end of welding cycles can be modified to prevent the formation of a ball at the end of the wire. This wire operation produces almost perfect restriking. The selected solution consists in injecting a current peak at end of cycle, which causes the wire end to become pointed.

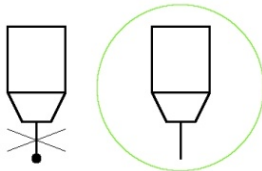

! NOTE

This current peak at end of cycle is not always desirable. For instance, when welding thin sheet metal, such this mechanism can cause a crater.

MIG/MAG Manual welding with Push-Pull gun (only K14168-2)

The Push-Pull gun is connected to the front of the power source.

It allows welding of light alloys with a wire diameter from 1.0 mm to 1.6 mm.

Assembly instruction

1. Preparing the sheath

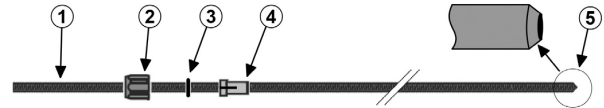

- Make sure the clamp (4), the o-ring (3) and the cap are in place (2).
- Give the end of the sheath on the torch side a conical shape (5) by using a suitable tool (e.g.: a pencil sharpener, a file).

2. Installing the sheath in the torch

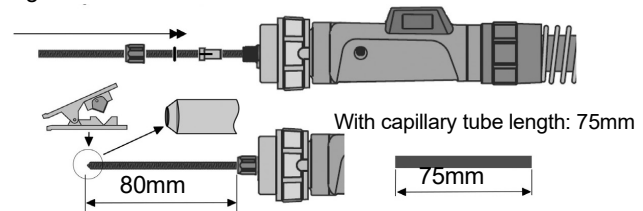

- Unwind and stretch out the torch bundle on a flat surface.
- Introduce the sheath in the bundle and ensure it has been inserted all the way inside the gun.
- Position the clamp (4) and the o-ring (3). Tighten the cap (2) on the torch connector.
- Cut the length of the sheath at the outlet at 80mm.
- Give the end of the sheath a conical shape by using a suitable tool (e.g.: a pencil sharpener, a file).
- Note: Using a capillary tube allows for a more rigid passage of the sheath in the MIG fitting.

3. Adjusting the pressure of the presser pin

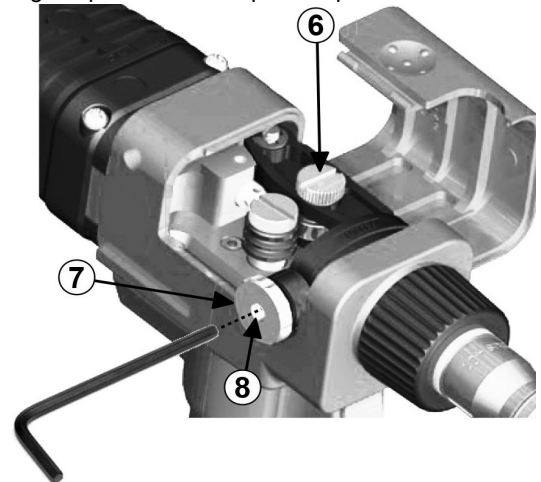

- In normal operating mode, the toothed wheel (7) that holds the casing into place must be screwed fully home.
- The adjustment is carried out with an adjustment screw (8).

Proceed as follows to adjust the pressure of the presser pin:

- Loosen the adjustment screw (8) so that the motor pin starts to slide.
- Gradually tighten the adjustment screw (8) again to prevent the motor pin from sliding.
- Never tighten the adjustment screw fully home (8).

List of synergies

SHORT ARC				
	0,6 mm	0,8 mm	1 mm	1,2 mm
Steel	M21	M21	M21	M21
	M14	M14	M14	M14
	M20	M20	M20	M20
	/	C1	C1	C1
CrNi	/	M11	M11	M11
	/	M12	M12	M12
	/	M12	M12	M12
AlSi	/	/	I1	I1
Al	/	/	/	I1
AlMg3	/	/	I1	I1
AlMg4,5 Mn	/	/	I1	I1
AlMg5	/	/	I1	I1
Cupro SI	/	I1	I1	I1
Cupro Alu	/	/	I1	I1
F CAW	/	/	M21	M21
RCW SD 100	/	/	M21	M21
	/	/	C1	C1
MCW : SD 200	/	/	M21	M21
BCW : SD 400	/	/	/	M21
	/	/	/	C1

PULSE				
	0,6 mm	0,8 mm	1 mm	1,2 mm
Steel	/	M21	M21	M21
	/	M14	M14	M14
	/	M20	M20	M20
CrNi	/	M11	M11	M11
	/	M12	M12	M12
	/	M12	M12	M12
AlSi	/	/	I1	I1
Al	/	/	/	I1
AlMg 3,5	/	/	I1	I1
AlMg4,5 Mn	/	/	I1	I1
AlMg5	/	/	I1	I1
Cupro SI	/	/	I1	I1
Cupro Alu	/	/	I1	I1
MCW SD 200	/	/	/	M21
BCW SD 400	/	/	/	M21

 **NOTE**

For any other synergies, please contact our agency.





GAZ TABLE	
Description on power source	Gas name
CO2	C1
Ar(82%) / CO2(18%)	M21
Ar(92%) / CO2(8%)	M20
Ar / CO2 / O2	M14
Ar / CO2 / H2	M11
Ar(98%) / CO2(2%)	M12
Ar / He / CO2	M12
Ar	I1

WIRE'S PART	
Description on power source	Designation
Steel	Steel Solid wire
F CAW	Cored wire for Zn coated steel
CrNi	Stainless steel solid wire
AlSi	
Al.	
AlMg3	Aluminium solid wire
AlNi4,5Mn	
AlMg5	
CuproSi	Copper Silicium solid wire
CuproAl	Copper Aluminum solid wire
BCW	Basic core wire
MCW	Metal core wire
RCW	Rutil core wire

Troubleshooting procedure

Servicing of electrical equipment must be performed by qualified personnel only

CAUSES	SOLUTIONS
GENERATOR IS ON WHILE THE FRONT PANEL IS OFF	
Power supply	CHECK THE MAINS SUPPLY (TO EACH PHASE)
DISPLAY OF THE MESSAGE E01-ond	
THE MAXIMUM STRIKING CURRENT OF THE POWER SOURCE WAS EXCEEDED	PRESS THE OK BUTTON TO CLEAR THE FAULT. IF THE PROBLEM PERSISTS, CALL CUSTOMER SUPPORT
DISPLAY OF THE MESSAGE E02 inu	
POOR RECOGNITION OF THE SOURCE OF POWER – ONLY AT START-UP –. Connectors in fault	Make sure that the ribbon cable between the inverter's main card and the cycle card is properly connected.
DISPLAY OF THE MESSAGE E07 400	
Inappropriate main voltage	Make sure that the main voltage is in the +/- 20% acceptable range of primary power supply of the power source.
DISPLAY OF THE MESSAGE E24 SE_n	
Temperature sensor in fault	MAKE SURE THAT CONNECTOR B9 IS PROPERLY CONNECTED TO THE CYCLE CARD (IF NOT, TEMPERATURE MEASUREMENT IS NOT PERFORMED) THE TEMPERATURE SENSOR IS OUT OF ORDER. CALL CUSTOMER SUPPORT
DISPLAY OF THE MESSAGE E25 -C	
Power source overheating Ventilation	Let the generator cool down The fault disappears by itself after several minutes Make sure that the inverter fan works.
DISPLAY OF THE MESSAGE E33- MEM-LIM This message indicates that the memory is no longer operational	
Malfunctioning during saving of memory	CALL CUSTOMER SERVICE.
DISPLAY OF THE MESSAGE E43 brd	
Electronic board in default	Call CUSTOMER SERVICE.
DISPLAY OF THE MESSAGE E50 H2o	
Cooler unit in default	MAKE SURE THAT COOLER UNIT IS WELL PLUGGED. CHECK COOLER UNIT (TRANSFORMER, WATERPUMP,...) IF NO COOLER UNIT IS USED, DESACTIVATE PARAMETER IN 
DISPLAY OF THE MESSAGE E63 IMO	
Mechanical problem	PRESSURE ROLLER IS TOO TIGHT. WIRE FEED HOSE IS CLOGGED WITH DIRT. THE LOCK OF THE WIRE FEED SPOOL AXLE IS TOO TIGHT.
DISPLAY OF THE MESSAGE E65-Mot	
Defective connectors Mechanical problem Power supply	Check the connection of the encoder ribbon cable to the wire feeder's motor. MAKE SURE THAT THE WIRE FEEDER ASSEMBLY IS NOT BLOCKED. Check the connection of the motor's power supply. Check F2 (6A) on the auxiliary power card.
DISPLAY OF THE MESSAGE E-71-PRO-DIA-MET-GAS	
HMI selector PROCESS-DIAMETER-METAL-GAS in default	Turn selector to unlock, after call customer service if always in default
DISPLAY OF THE MESSAGE StE PUL	
Inverter not well recognized	Call Customer Service

DISPLAY OF THE MESSAGE I-A-MAHX	
Maximum current of power source reached	Decrease wire speed or arc voltage
DISPLAY OF THE MESSAGE bPX-on	
Message indicating that  or  is kept depressed at unexpected times	Push  to unlock, after call customer service if always in default
DISPLAY OF THE MESSAGE SPEXXX	
Wire feeding is always activated involuntarily	Check the wire feeding button isn't blocked Check the connection of this button and electronic board
DISPLAY OF THE MESSAGE LOA DPC	
UPDATE software by PC is activated involuntarily	Stop and start e power source, after call customer service if always in default
TRIGGER FAULT	
This message is generated when the trigger is pulled at a time when it can accidentally cause starting a cycle.	Trigger pulled before the power source is turned on or during a reset due to a fault.
NO WELDING POWER - NO ERROR MESSAGE	
Power cable not connected Power source failure	Check the connection of the ground strip and the torch IN COATED ELECTRODE MODE, CHECK FOR VOLTAGE BETWEEN THE WELDING TERMINALS AT THE FRONT OF THE GENERATOR. IF NO VOLTAGE, CALL CUSTOMER SUPPORT.
WELDING QUALITY	
Wrong calibration Change of torch and/or ground strip or work piece Unstable or fluctuating welding Unstable or fluctuating welding Limited range of adjustment settings Poor power source power supply	Check the fine setting parameter (RFP = 0) Perform re-calibration. (Verify proper electrical contact at the welding circuit). Make sure that the sequencer is not activated. Check the Hot Start and the down-slope. Select the manual mode. The limitation is imposed by synergy compatibility rules. IF USING RC JOB MAKE SURE YOU HAVE NOT ACTIVATED THE PASSWORD-OPERATED SETTING LIMITATION Check proper connection of the three power supply phases.
OTHER	
Wire stuck in the molten pool or at the contact tube Display of the triG message when turning the power on.	Optimize the arc extinction parameters: PR spray and post retract The TtriG message is displayed if the trigger is activated before switching on the welding set
<p>If the problem persists, you may reset the parameters to factory defaults. For this purpose, with the welding unit turned off, select the Setup position at the front panel selector, press  and keep it depressed while turning on the generator.</p> <p>PLEASE NOTE Consider recording your work parameters first, because this operation will erase all the programmes saved in memory. If RESETTING to factory values does not solve the problem, call Customer Support.</p>	

Transport & Lifting



WARNING

Falling equipment can cause injury and damage to unit.

During transportation and lifting with a crane, adhere to the following rules:

- Power source does not include the eye bolt which can be used to transport or lifting the machine.
- To lift use of suitable lifting equipment capacity.
- To lifting and transport use a travers and minimum two belts.
- Lift only power source without gas cylinder, cooler and wire feeder, or/and any other accessories.

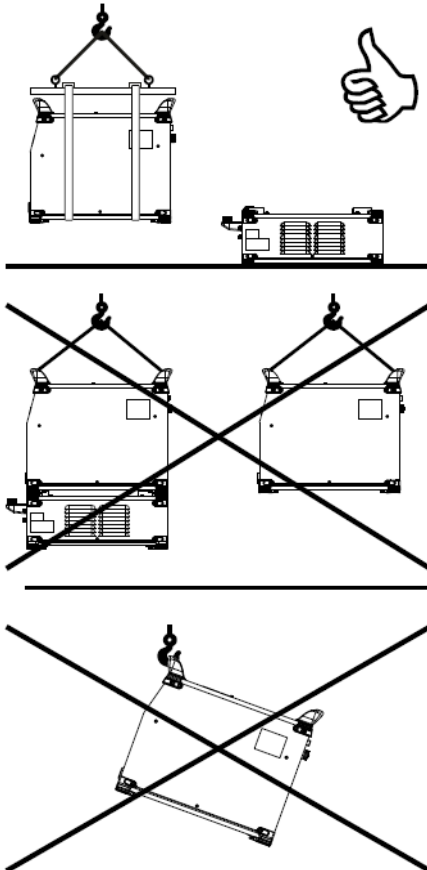

Maintenance

General

Twice a year, depending on the use of the device, inspect the following:

- cleanliness of the power source
- electrical and gas connections
- Perform calibration of the current and voltage settings.
- Check electrical connections of the power, control and power supply circuits.
- Check the condition of insulation, cables, connections and pipes.
- Perform a compressed air cleaning

WARNING

Never carry out cleaning or repair work inside the device before making sure that the unit has been completely disconnected from the mains.

Dismantle the generator panels and use suction to remove dust and metal particles accumulated between the magnetic circuits and the windings of the transformer.

Work must be performed using a plastic tip to avoid damage to the insulation of the windings.

At each start-up of the welding unit and prior to calling customer support for technical servicing, please check that:

- Power terminals are not improperly tightened.
- The selected mains voltage is correct.
- There is proper gas flow.
- Type and diameter of the wire. Torch condition.

Torch

REGULARLY CHECK THE PROPER TIGHTNESS OF THE CONNECTIONS OF THE WELDING CURRENT SUPPLY. MECHANICAL STRESSES RELATED TO THERMAL SHOCKS TEND TO LOOSEN SOME PARTS OF THE TORCH, PARTICULARLY:

- The contact tube
- The coaxial cable
- The welding nozzle
- The quick connector

Check that the gasket of the gas inlet spigot is in good condition.

Remove the spatter between the contact tube and the nozzle and between the nozzle and the skirt.

Spatter is easier to remove if the procedure is repeated at short intervals.

Do not use hard tools that may scratch the surface of these parts and cause spatter to become attached to it.

Blow out the liner after each change of a spool of wire. Carry out this procedure from the side of the quick fitting connector plug of the torch.

If necessary, replace the wire inlet guide of the torch.

Severe wear of the wire guide may cause gas leaks towards the rear of the torch.

The contact tubes are designed for long use. Nevertheless, the passage of wire causes them to wear off, widening the bore more than the permissible tolerances for good contact between the tube and the wire.

The need to replace them becomes clear when the metal transfer process becomes unstable, all the settings of the work parameters remaining otherwise normal.

Rollers and wire guide

UNDER NORMAL CONDITIONS OF USE, THESE ACCESSORIES HAVE A LONG SERVICEABLE LIFE BEFORE THEIR REPLACEMENT BECOMES NECESSARY.

Sometimes, however, after being used over a period of time, excessive wear or clogging due to adhering deposits may be noted.

To minimize such harmful effects, make sure the wire feeder plate remains clean. The motor reduction unit requires no maintenance.



WARNING

For any maintenance or repair operations it is recommended to contact the nearest technical service center or Lincoln Electric. Maintenance or repairs performed by unauthorized service centers or personnel will null and void the manufacturer's warranty.

The frequency of the maintenance operations may vary in accordance with the working environment. Any noticeable damage should be reported immediately.

- Check cables and connections integrity. Replace, if necessary.
- Keep clean the machine. Use a soft dry cloth to clean the external case, especially the airflow inlet / outlet louvers.



WARNING

Do not open this machine and do not introduce anything into its openings. Power supply must be disconnected from the machine before each maintenance and service. After each repair, perform proper tests to ensure safety.

Customer Assistance Policy

The business of The Lincoln Electric Company is manufacturing and selling high quality welding equipment, consumables, and cutting equipment. Our challenge is to meet the needs of our customers and to exceed their expectations. On occasion, purchasers may ask Lincoln Electric for advice or information about their use of our products. We respond to our customers based on the best information in our possession at that time. Lincoln Electric is not in a position to warrant or guarantee such advice, and assumes no liability, with respect to such information or advice. We expressly disclaim any warranty of any kind, including any warranty of fitness for any customer's particular purpose, with respect to such information or advice. As a matter of practical consideration, we also cannot assume any responsibility for updating or correcting any such information or advice once it has been given, nor does the provision of information or advice create, expand or alter any warranty with respect to the sale of our products.

Lincoln Electric is a responsive manufacturer, but the selection and use of specific products sold by Lincoln Electric is solely within the control of, and remains the sole responsibility of the customer. Many variables beyond the control of Lincoln Electric affect the results obtained in applying these types of fabrication methods and service requirements.

Subject to Change – This information is accurate to the best of our knowledge at the time of printing. Please refer to www.lincolnelectric.com for any updated information.

WEEE

07/06



Do not dispose of electrical equipment together with normal waste!

In observance of European Directive 2012/19/EC on Waste Electrical and Electronic Equipment (WEEE) and its implementation in accordance with national law, electrical equipment that has reached the end of its life must be collected separately and returned to an environmentally compatible recycling facility. As the owner of the equipment, you should get information on approved collection systems from our local representative.

By applying this European Directive you will protect the environment and human health!

Spare Parts

12/05

Part List reading instructions

- Do not use this part list for a machine if its code number is not listed. Contact the Lincoln Electric Service Department for any code number not listed.
- Use the illustration of assembly page and the table below to determine where the part is located for your particular code machine.
- Use only the parts marked "X" in the column under the heading number called for in the assembly page (# indicate a change in this printing).

First, read the Part List reading instructions above, then refer to the "Spare Part" manual supplied with the machine that contains a picture-descriptive part number cross-reference.

REACH

11/19

Communication in accordance with Article 33.1 of Regulation (EC) No 1907/2006 – REACH.

Some parts inside this product contain:

Bisphenol A, BPA,	EC 201-245-8, CAS 80-05-7
Cadmium,	EC 231-152-8, CAS 7440-43-9
Lead,	EC 231-100-4, CAS 7439-92-1
Phenol, 4-nonyl-, branched,	EC 284-325-5, CAS 84852-15-3

in more than 0,1% w/w in homogeneous material. These substances are included in the "Candidate List of Substances of Very High Concern for Authorisation" of REACH.

Your particular product may contain one or more of the listed substances.

Instructions for safe use:

- use according to Manufacturer instructions, wash hands after use;
- keep out of reach of children, do not put in mouth,
- dispose in accordance with local regulations.

Authorized Service Shops Location

09/16

- The purchaser must contact a Lincoln Authorized Service Facility (LASF) about any defect claimed under Lincoln's warranty period.
- Contact your local Lincoln Sales Representative for assistance in locating a LASF or go to www.lincolnelectric.com/en-gb/Support/Locator.

Electrical Schematic

Refer to the "Spare Part" manual supplied with the machine.

Accessories

K14105-1	COOLARC 46
W000275904	REMOTE CONTROL (10m, WFS and V control)
W000375730	TWO-WHEELED UNDERCARRIAGE
K14096-1	FOUR-WHEELED UNDERCARRIAGE (required K14193-1)
K14193-1	CART ADAPTER KIT
K14192-1	CONTROL PANEL COVER KIT
K10158-1	ADAPTER FOR SPOOL TYPE B300
LINC GUN™	
W10429-24-3M	LGS2 240 G-3.0M MIG GUN AIR COOLED
W10429-24-4M	LGS2 240 G-4.0M MIG GUN AIR COOLED
W10429-24-5M	LGS2 240 G-5.0M MIG GUN AIR COOLED
W10429-25-3M	LGS2 250 G-3.0M MIG GUN AIR COOLED
W10429-25-4M	LGS2 250 G-4.0M MIG GUN AIR COOLED
W10429-25-5M	LGS2 250 G-5.0M MIG GUN AIR COOLED
W10429-36-3M	LGS2 360 G-3.0M MIG GUN AIR COOLED
W10429-36-4M	LGS2 360 G-4.0M MIG GUN AIR COOLED
W10429-36-5M	LGS2 360 G-5.0M MIG GUN AIR COOLED
W000385860	PROMIG PP 341 Standard (8m, swan neck 45°)
W000385861	PROMIG PP 341 Potentiometer (8m, swan neck 45°)
W000385862	PROMIG PP 441W Standard (8m, swan neck 45°)
W000385863	PROMIG PP 441W Potentiometer (8m, swan neck 45°)
ROLL KIT FOR SOLID WIRES	
KP14017-0.8	DRIVE ROLLS V0.6-0.8 DIA37
KP14017-1.0	DRIVE ROLLS V0.8-1.0 DIA37
KP14017-1.2	DRIVE ROLLS V1.0-1.2 DIA37
ROLL KIT FOR ALUMINIUM WIRES	
KP14017-1.2A	DRIVE ROLLS U1.0-1.2 DIA37
W000277622	ALUMINUM WELDING KIT 1.0-1.2
ROLL KIT FOR CORED WIRES	
KP14017-1.1R	DRIVE ROLLS VK0.9-1.1 DIA37