

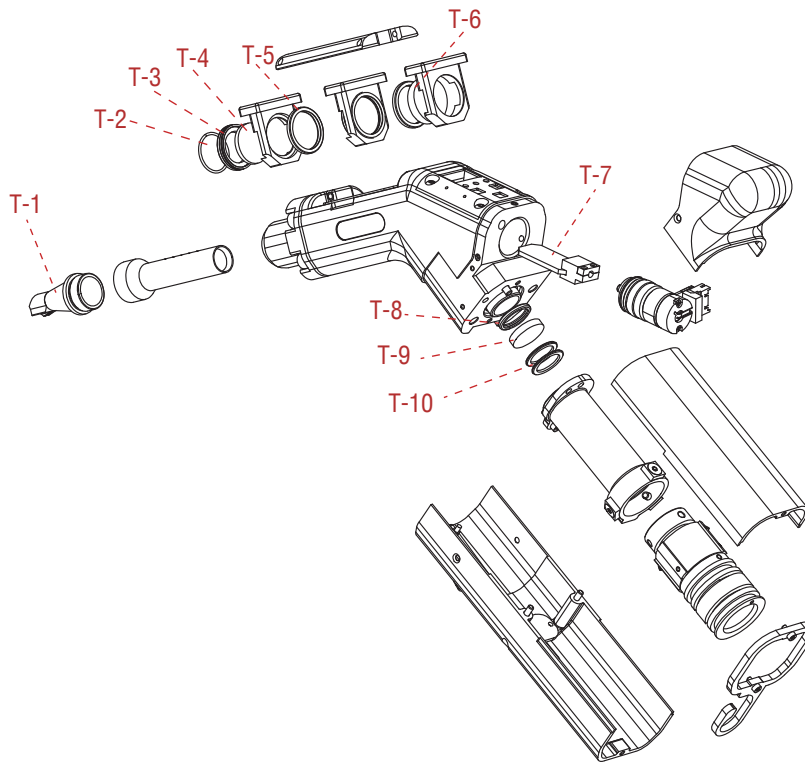







Handheld Welding Torch

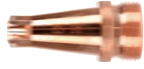

No.	Order No.	Description
	3.13.08.0044	Handheld welding torch (LWH20-4000-ZC01) (Standard Model: with LCD display, operational buttons, and indicator lamps)
	3.13.04.0044	welding nozzle 1.2 (AS-12)
	3.13.04.0045	welding nozzle 1.6 (BS-16)
	3.13.04.0046	welding nozzle 1.2 (CS-12)
	3.13.04.0040	welding nozzle 1.2 (ES-12)
	3.13.04.0041	welding nozzle 1.6 (FS-16)
	3.13.04.0047	welding nozzle (C Non-wire feed)
	3.13.04.0056	Spot calibration nozzle (LWH20-4012-01)
	3.13.04.0024	Cleaning nozzle (LWH2K-QXPZ-A-001)

T-1

(Continued on next page)



Handheld Welding Torch

No.		Order No.	Description
T-2		3.13.03.0085	Flat washer (LWH20-4002-04)
T-3		3.13.04.0035	Protective lens retaining ring (LWH20-4002-03)
T-4		3.13.05.0004	Protective lens (D18*2 2KW)
T-5		3.13.99.0002	End face gasket seal (LWH2K-A-050)
T-6		3.13.10.0033	Focus lens (D20mm*F150mm Daheng)
T-7		3.13.03.0095	Reflection mirror assembly (LWH20-40PJ-01)
T-8		3.13.99.0374	End face gasket seal (LWH20-4004-02)
T-9		3.13.10.0002	Collimating lens (D16mm*F50mm Daheng)
T-10		3.13.04.0054	Focus adjustment spacer (LWH20-4004-03)