

Never compromise on quality
质量永不止步

TRM[®] 特尔玛

TRM LWH Handheld Laser Welding Machine

Infinite Connections

Engineered to Become A **Industrial-Grade** Welding Workstation

LWH2000-P / LWH1500-P



ISO OERLIKON AG Schweißtechnik
CH-5737 Menziken AG – Tel. +41 (0)62 771 83 05
E-Mail info@iso-oerlikon.ch – www.iso-oerlikon.ch

Scalable Bus Control Design

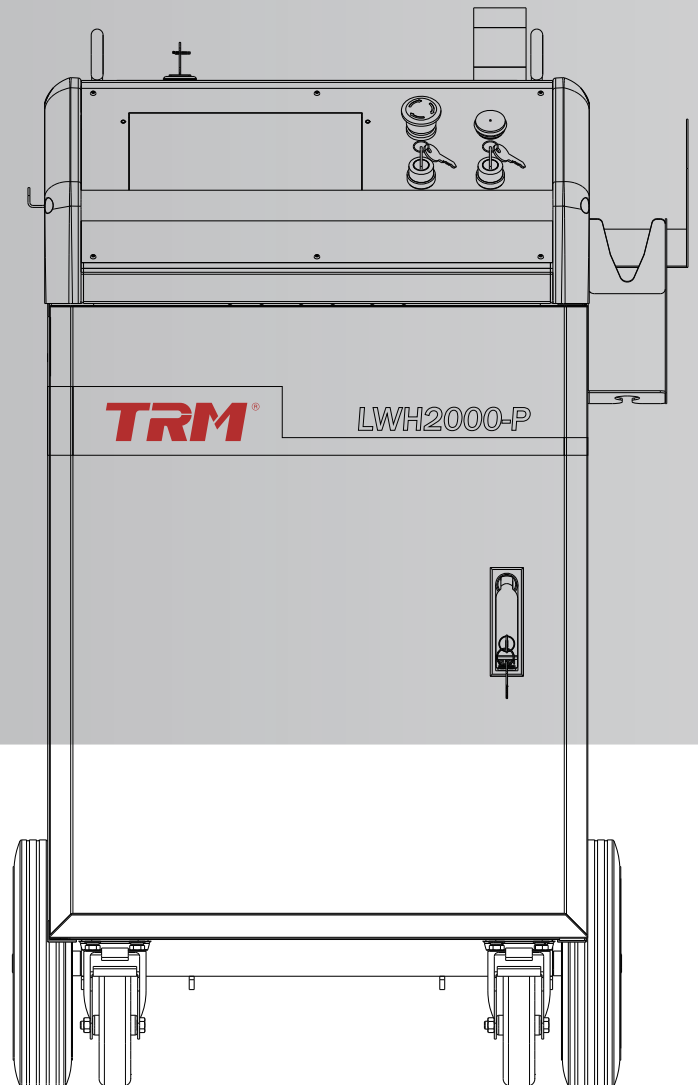

Handheld Laser Welding Machine

The new generation handheld laser welding machine adopts bus control design, modular parallel laser generator, chiller, human-machine interface, main control board, solenoid valve, and galvanometer, etc. It also provides an open bus control interface, enabling high-response collaborative operation of various modules to achieve a more perfect welding result.



High-response Dedicated Wire Feeder

Thanks to the advantages of bus control, our independently developed laser welding-dedicated wire feeder can leverage its product strengths even further. It offers a faster response time, more stable wire feeding, and features the most sensitive wire feeding, wire retraction, and alarm functions, making laser wire filling welding even smoother.



Advanced Self-developed Torch

With the significant advantages of bus control design, our independently developed handheld laser welding torch also features a more comprehensive and powerful set of functions. It enables real-time control of the emission status and remote adjustment of welding parameters on the welding site, greatly improving work efficiency.



Robust Cooling and Real-time Feedback

Our independently developed high-capacity chiller, integrated into the bus control design, maximizes the advantages of liquid cooling systems by rapidly reducing temperatures and providing continuous cooling. It also boasts the fastest feedback and alarm response, ensuring worry-free operation.

Perfect for Prolonged High-precision Welding

Wire Feeder

- The wire feeder supports four parallel connections, with **millisecond-level** response speed.
- After a hundred wire feeding tests, the wire feeding accuracy error is **within one thousandth**.

Laboratory test data; actual performance may vary based on on-site conditions.



Chiller

Continuous full-power laser emission in a working environment of 10°C to 40°C for a 2KW laser.

Laboratory test data; actual performance may vary based on on-site conditions.



Perfect for Prolonged High-precision Welding



More Humanized Design of the Laser Welding Torch

- The welding torch features an ergonomic handle, QBH anti-loosening design, wear-resistant sheath, and V0 flame-retardant materials.
- Equipped with a standard head indicator light, it provides real-time display of equipment status, laser emission, and alarm status.
- Optional LCD operation for the torch head allows for portable adjustment of laser power, swing width, swing frequency, wire feeding speed, and quick access to process parameters.



Optional handheld teaching pendant available.

Intelligent Welding Process Parameter Database



Beginner-friendly and Quickly Accessible

A process parameter expert database authored by welding industry experts, with built-in laser parameters tailored to different materials and thicknesses. Even beginners can produce aesthetically pleasing, high-quality welds quickly.





Enhanced Storage Capabilities

The expert database for the next-generation laser welding machine has been specifically designed for easy parameter retrieval and storage, enabling quick sharing of parameter databases between machines, reducing the time spent on parameter recall and adjustment.

Comprehensive Safety Protection System



Double-button

Unique Dual-button Emission

TRM uses a double-button light-emitting design for the self-developed torch body to ensure the safety of users in case of accidentally touching either of the two buttons. The light-emitting welding can only be carried out by pressing both buttons simultaneously.

The Incorporation of Safety Relays

The use of high-quality components, unique dual-button emission, the incorporation of safety relays, and even integration with the door locks of the laser safety enclosure all contribute to the meticulous design of every safety aspect of our product. This ensures that our product meets safety standards even more stringent than CE certification.





Laser Welding Protection Enclosure

Strictly adhering to the certification requirements of the EU CE60825, TRM's independently developed laser welding protection enclosure achieves secure interlocking with the LWH Plus series laser welding machines.

Providing you with the most comprehensive safety protection assurance.

- The laser remains in a closed state when the door is open;
- Unauthorized personnel cannot pass through the access control;
- External indicator lights provide real-time display of the laser welding machine's operational status.

High Integration Welding Workstation



Infinite Connectivity Possibilities

In the framework of bus control design, the open connection of different modules will provide the handheld laser welding system with unlimited possibilities, whether facing functional expansion, changes in scenarios, or adjustments to usage requirements. This marks a groundbreaking development within the industry.

Expansion interfaces:

- Handheld Teaching Pendant
- Precision Wire Feeding System
- Dual Wire Feeder
- Welding Protection Enclosure
- Welding Helmet
- Robot Control
- ∞



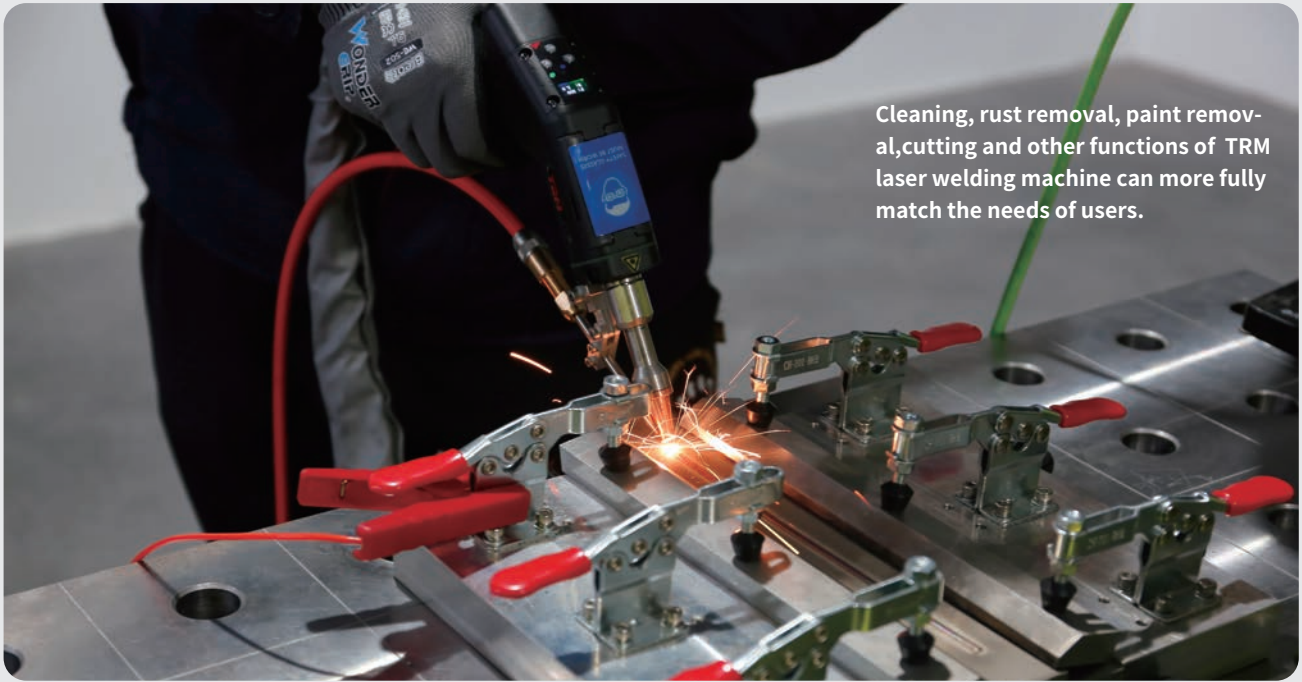

Cleaning, rust removal, paint removal, cutting and other functions of TRM laser welding machine can more fully match the needs of users.

Extremely Robust and Highly Stable Performance

TRM has achieved stable and surprising performance in key data of laser welding machine such as the penetration depth in self-fusion stitch welding and the strength in butt welding.

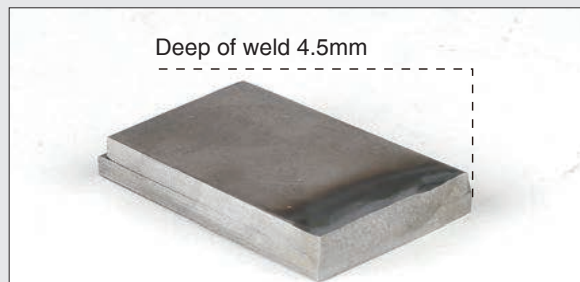

The performance of tests in the laboratory.

Comparative Analysis of Welding

Item	Traditional welding systems	TRM laser welding systems
Heat-affected-zone	Large	Small
Distortion & Deformation	High	Very low
Weld appearance	Rough and irregular	Clean and beautiful
Welding speed	Average	4X
Operation difficulty	High	Low
Operator experience required	Professional	Beginner friendly
Wobble welding	No	Up to 5 mm
Physical hazard	Large radiation and smoke	Low radiation and environmental friendly
Labor	High	Low
Time	High	Low
Space occupied	High	Low

Welding Process Parameters



Angle



Corner



Butt

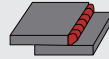

Overlap



Fillet

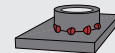

Point

Material	Thickness (mm)	Power (W)	Scan width (mm)	Wire feed speed (m/min)
Stainless steel	1	400	2	0.8
	6	2000	4	0.6
Galvanized steel	1	300	2	0.8
	6	2000	4	0.6
Mild steel	1	400	2	0.8
	6	2000	4	0.6
Aluminum	1	550	2	0.9
	5	1800	3	0.6

*For more process parameters, please refer to the expert database.

Main Technical Parameters

Item	Parameter	
Item No.	LWH1500-P	LWH2000-P
Conduction type	Optical fiber	Optical fiber
Power supply	230V~ 40A 50/60Hz	230V~ 50A 50/60Hz
Laser center wavelength	1080±10nm	1080±10nm
Laser power	1500W	2000W
Laser cooling	Water cooling	Water cooling
Fiber length	5m or 10m	5m or 10m
Protective gas type	Argon, nitrogen	Argon, nitrogen
Power consumption of the whole machine	8kw	11kw
Air pressure requirements	Hand-held laser welding4-6Bar	Hand-held laser welding4-6Bar
Welding cabinet size (mm)	1130*690*1040mm	1130*690*1040mm
Wire feeder size	692*246*391mm	692*246*391mm
Whole machine net weight	about 197kg	about 197kg
Operating ambient temperature range	10 to 40 °C	10 to 40 °C
Welding thickness (suggestion)	0.4-4mm	0.4-6mm
Welding gap requirement	Below 0.5mm	Below 0.5mm
Wire diameter	0.8mm, 1mm, 1.2mm, 1.6mm	0.8mm, 1mm, 1.2mm, 1.6mm
Refrigerant model	R410A	R410A

Laser welding system

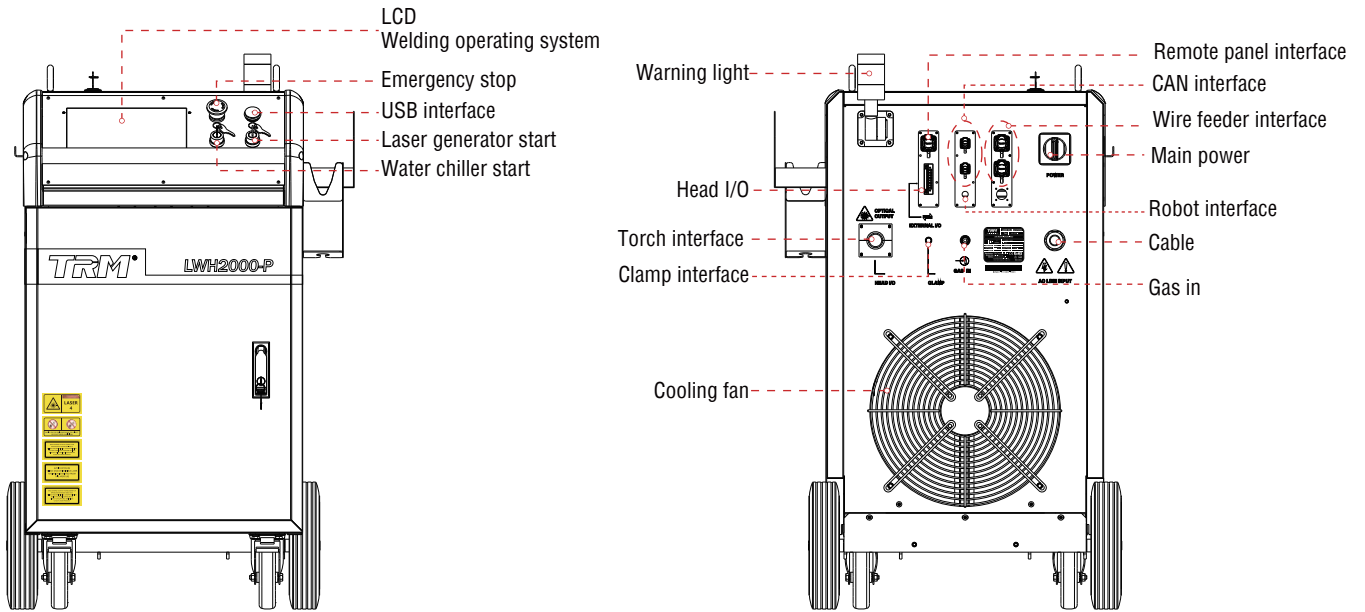

Control Panel and Connections

Water chiller



Order No.	Description
3.13.07.0305	Integrated handheld laser welding system (LWH1000-P-BFL05Y)
3.13.07.0306	Integrated handheld laser welding system (LWH1500-P-BFL05Y)
3.13.07.0307	Integrated handheld laser welding system (LWH2000-P-BFL05Y)
3.13.07.0308	Integrated handheld laser welding system (LWH1000-P-BFL10Y)
3.13.07.0309	Integrated handheld laser welding system (LWH1500-P-BFL10Y)
3.13.07.0310	Integrated handheld laser welding system (LWH2000-P-BFL10Y)





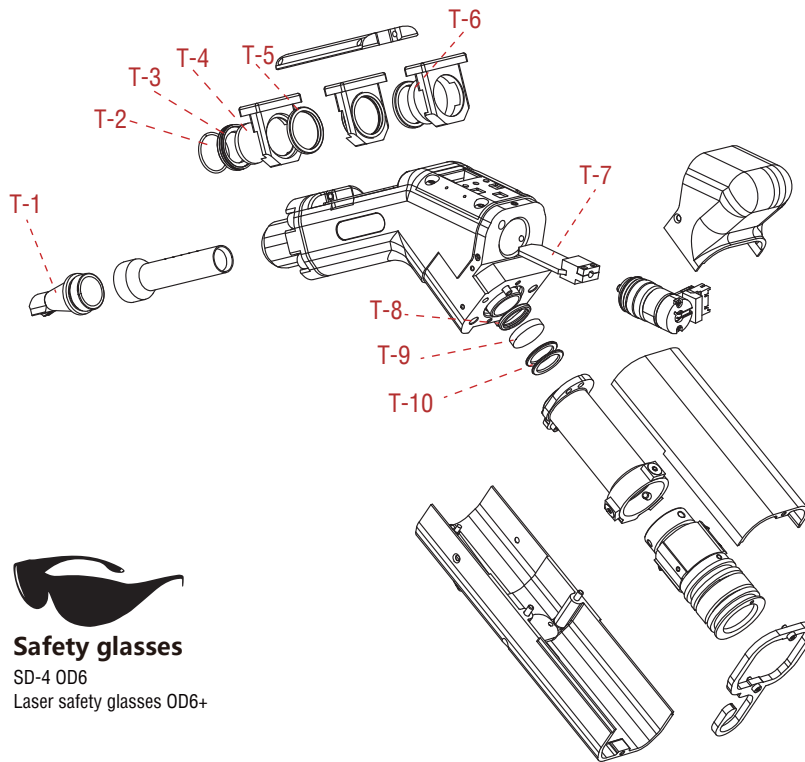



*Including welding torch and 5/10-meter fiber optic cable

Handheld Welding Torch



Safety glasses
SD-4 OD6
Laser safety glasses OD6+



No.	Order No.	Description
	3.13.08.0044	Handheld welding torch (LWH20-4000-ZC01) (Standard Model: with LCD display, operational buttons, and indicator lamps)
	3.13.04.0044	welding nozzle 1.2 (AS-12)
	3.13.04.0045	welding nozzle 1.6 (BS-16)
	3.13.04.0046	welding nozzle 1.2 (CS-12)
	3.13.04.0040	welding nozzle 1.2 (ES-12)
	3.13.04.0041	welding nozzle 1.6 (FS-16)
	3.13.04.0047	welding nozzle (C Non-wire feed)
	3.13.04.0056	Spot calibration nozzle (LWH20-4012-01)
	3.13.04.0024	Cleaning nozzle (LWH2K-QXPZ-A-001)

T-1





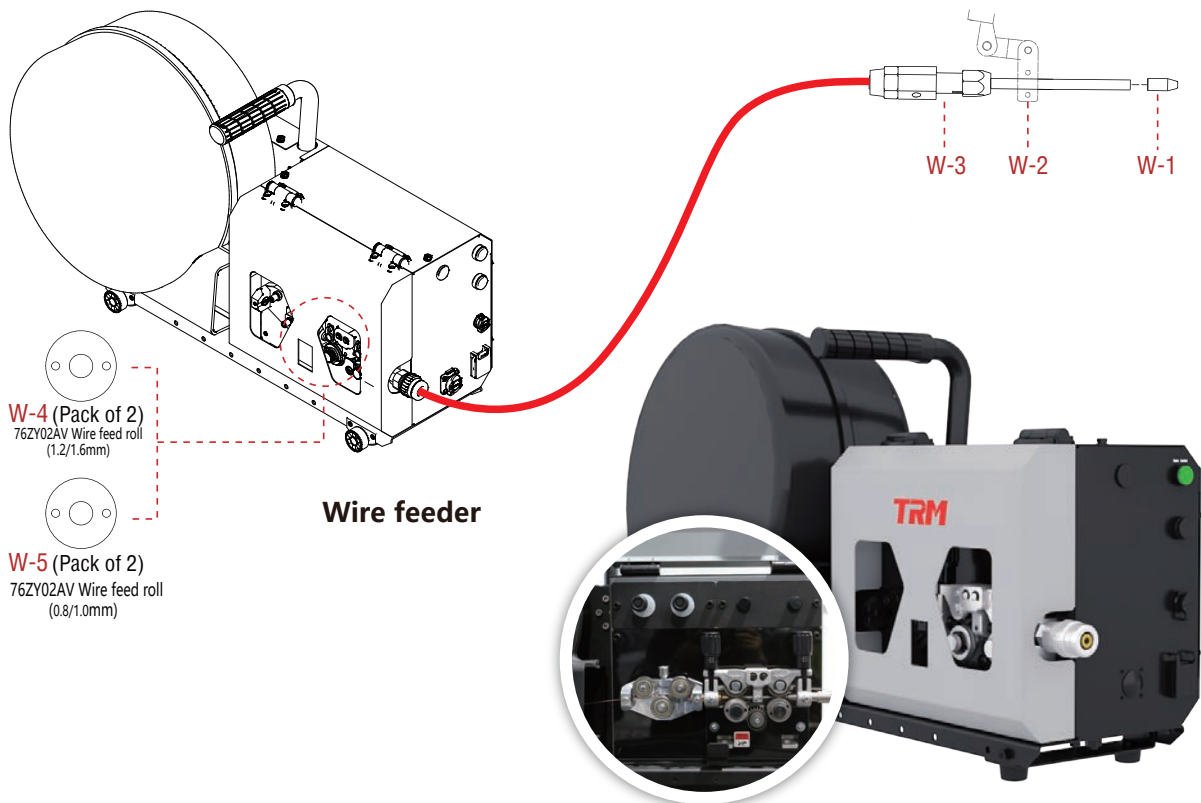

(Continued on next page)

Handheld Welding Torch

No.		Order No.	Description
T-2		3.13.03.0085	Flat washer (LWH20-4002-04)
T-3		3.13.04.0035	Protective lens retaining ring (LWH20-4002-03)
T-4		3.13.05.0004	Protective lens (D18*2 2KW)
T-5		3.13.99.0002	End face gasket seal (LWH2K-A-050)
T-6		3.13.10.0033	Focus lens (D20mm*F150mm Daheng)
T-7		3.13.03.0095	Reflection mirror assembly (LWH20-40PJ-01)
T-8		3.13.99.0374	End face gasket seal (LWH20-4004-02)
T-9		3.13.10.0002	Collimating lens (D16mm*F50mm Daheng)
T-10		3.13.04.0054	Focus adjustment spacer (LWH20-4004-03)





Wire Feeder



No.	Order No.	Description
	3.13.09.0200	Wire feeder (WF-01A)
W-1 	3.13.04.0004	Wire feeding nozzle D0.8 (LWH2K-SSPZ-A-001)
	3.13.04.0011	Wire feeding nozzle D1.0 (LWH2K-SSPZ-A-002)
	3.13.04.0012	Wire feeding nozzle D1.2 (LWH2K-SSPZ-A-003)
	3.13.04.0013	Wire feeding nozzle D1.6 (LWH2K-SSPZ-A-004)
W-2 	3.13.04.0015	Wire feed bracket (LWH2K-SSPZ-A)
W-3 	3.13.09.0206	Wire feed tube assembly (WF01A-FJ-01-3.3M)
W-5 	3.11.03.0005	76ZY02AV Wire feed roll (1.2/1.6mm)
W-6 	3.11.03.0022	76ZY02AV Wire feed roll (0.8/1.0mm)



Optional Consumables

	Order No.	Description
	3.13.08.0045	Handheld welding torch (LWH20-4000-ZC02) (Economy Model: with indicator lamps)
	3.13.07.0284	Robot connection cable (8-meter) LWH20-1230-10
	3.13.09.0199	Double wire feeder bracket (WF01A-5200-00)
	3.13.11.0010	Remote panel (RP01-A)

Application Industries



Furniture



Household Supplies

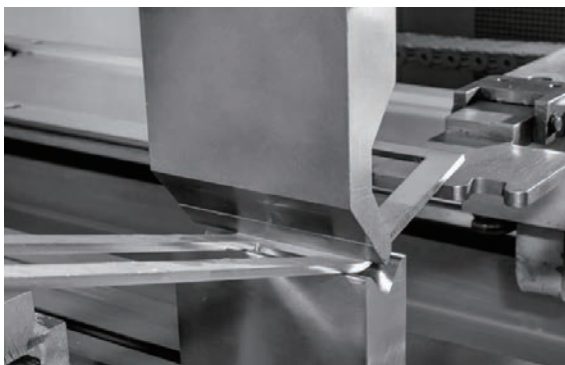

Sheet Metal



Mould



Light Fixture



Hardware



Door & Window



Advertising



ISO OERLIKON AG Schweisstechnik

CH-5737 Menziken AG – Tel. +41 (0)62 771 83 05

E-Mail info@iso-oerlikon.ch – www.iso-oerlikon.ch